

Si3540 Programmable Step Motor Drive



Features

- *Si™*, Si Command Language (SCL) or SiNet Hub programming languages included with drive
- AC input 110 V or 220 V switch selectable, 50-60 Hz
- DC bus voltage 35 VDC full load, 40 VDC nominal
- Software selectable motor current from 0.2 – 3.5 amps/phase
- Software selectable motor resolution from 2,000 to 50,800 steps per revolution
- Software selectable idle current reduction 0, 25%, 50% or 100%
- Eight optically isolated programmable inputs 5 – 24 VDC, 2,200 ohms internal resistance. Can be configured for sinking (NPN) or sourcing (PNP) signals.
- Three optically isolated programmable outputs 12 – 24 VDC, 100mA maximum
- RS-232 for PC/MMI communications
- 140 watts of usable power
- Screw terminal connectors
- Dual, MOSFET H-bridge, 3 state, pulse width modulated amplifier switching at 20 – 30 KHz
- Ideal for 4, 6 or 8 leaded step motors NEMA sizes 11, 14, 17 and 23
- Optional Man Machine Interface (MMI) allows machine operator to enter specific motion parameters
- CE and TUV compliant

Description

The Si3540 is a programmable stepper drive/indexer packaged in a rugged steel case painted black with white epoxy silkscreen. Integral heat sink, mounting brackets, switch covers and connectors are included with each Si3540. The drive/indexer has been matched with twelve recommended NEMA 11, 14, 17 & 23 motors and comes

with all operating software necessary to create a complete stepper motion solution.

The Si3540 includes Applied Motion Products', Windows based, *Si™* software language for quick set up and ease of use. The *Si™* is ideal for stand-alone operation. For more experienced users, with software development expertise, the Si3540 also comes with Applied's *Si™* Command Language (SCL) programming instruction set. SCL allows for control of the *Si™* drive from a host PC or PLC thus permitting the user to perform a variety of motion, I/O tasks and system status retrieval via the host.

Multiple axis applications are handled by our SiNet™ Hub Programmer, which gives you the ability to control up to 8 *Si™* drives, either stepper or servo on the same hub. Not only can you coordinate up to eight motors, the hub also has access to the inputs and outputs of all the drives, providing your program with up to 64 inputs and 24 outputs. You can also use Applied's MMI to interface the drives with the machine operator.

Factory set to operate at 110-volt input; the Si3540 can be set by the user to operate at 220-volt input by a simple switch selection.

Pluggable screw terminal blocks are provided for the I/O, motor and AC power input. Mating connectors, programming cable with computer interface connector as well as all operating software are provided with each *Si™* drive.

The Si3540 is both CE and TUV compliant.

Si3540 Technical Specifications

POWER AMPLIFIER:

AMPLIFIER TYPE	MOSFET, dual H-Bridge.
CURRENT CONTROL	3 state, pulse width modulated, switching at 20–30 KHz.
OUTPUT CURRENT	0.2–3.5 amps, software selectable.
POWER SUPPLY	Linear, toroidal transformer based for high reliability and low noise. 110 or 220 VAC input, switch selectable. 50/60 Hz.
DC BUS VOLTAGE	DC voltage at nominal line voltage: 35 VDC full load, 40 VDC no load.
AC INPUT VOLTAGE	110 or 220 VAC (switch selectable) 50/60 Hz.
MAXIMUM OUTPUT POWER	140 watts.
IDLE CURRENT REDUCTION	0%, 25%, 50%, or 100% software selectable.
MOTOR RESOLUTION	13 resolutions. Steps per revolution with 1.8° motor: 2000, 5000, 10000, 12800, 18000, 20000, 21600, 25000, 25400, 25600, 36000, 50000, 50800, software selectable.
STATUS LED'S	AC power (red).

CONTROLLER (INDEXER) SECTION Si3540:

SERIAL COMMUNICATION	RS-232 programming port.
MOTION UPDATE	12800 Hz.
INPUTS	8 user programmable inputs. Can be used for triggering, sensing, homing, branching, jogging or limits. 5-24 VDC optically isolated.
OUTPUTS	3 general purpose, optically isolated 12–24 VDC outputs for interfacing to other equipment. Open collector and emitter. 100 mA max.
PARAMETER RANGES	Distance: 1 to 16,000,000 steps. Speed: .025 to 50 revolutions per second (in any microstep resolution). Acceleration: 1 to 3,000 rev/sec/sec. Deceleration: 1 to 3,000 rev/sec/sec (set independently from acceleration). Time Delays: 0.01 to 300 seconds. Output Pulse Widths: 2 to 500 milliseconds. Iterations per repeat loop: 1 to 65,535.
OPTIONAL OPERATOR INTERFACE (MMI)	NEMA 4/12 rated (splash proof & dust proof). 4 x 20 characters liquid crystal display (LCD), standard or backlit. 20 key membrane keypad. Overall size: 4.9 x 4.9 x 1.42 inches.

SYSTEM SPECIFICATIONS:

OVERALL SIZE	2.25 x 7.8 x 5.40 inches.
CHASSIS MATERIAL	Aluminum, black anodized with integral heat sink.
WEIGHT	4 lbs.
AMBIENT TEMPERATURE	0° to 50°C (32° to 122°F).
HUMIDITY	Maximum of 90% non-condensing.
CONNECTORS	Screw terminal connectors for input power and motor, and I/O signals.
MOTORS	Can drive 4, 6 or 8 lead motors, NEMA sizes 11, 14, 17 & 23.
CASE	Steel with black paint and white epoxy silk screen. Includes switch covers.
AGENCY APPROVAL	CE & TUV.

Si3540 Technical Specifications

MECHANICAL OUTLINE

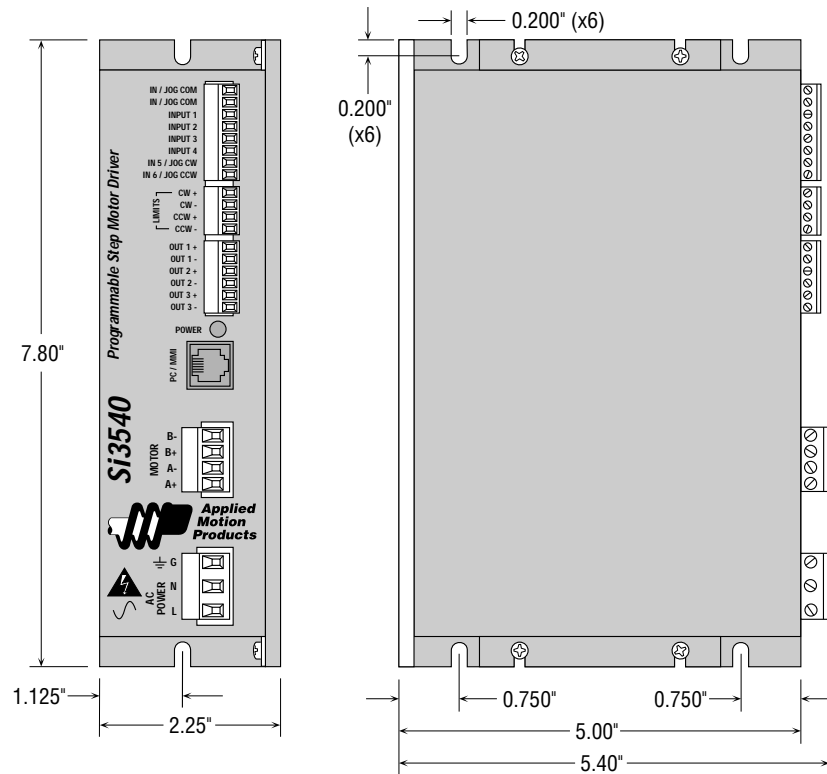

BLOCK DIAGRAM

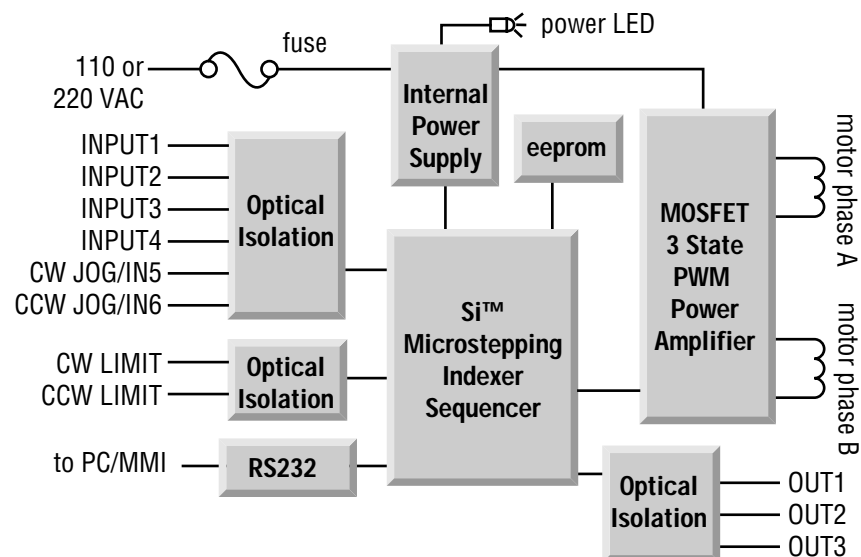

Si3540 Connectors and Switches

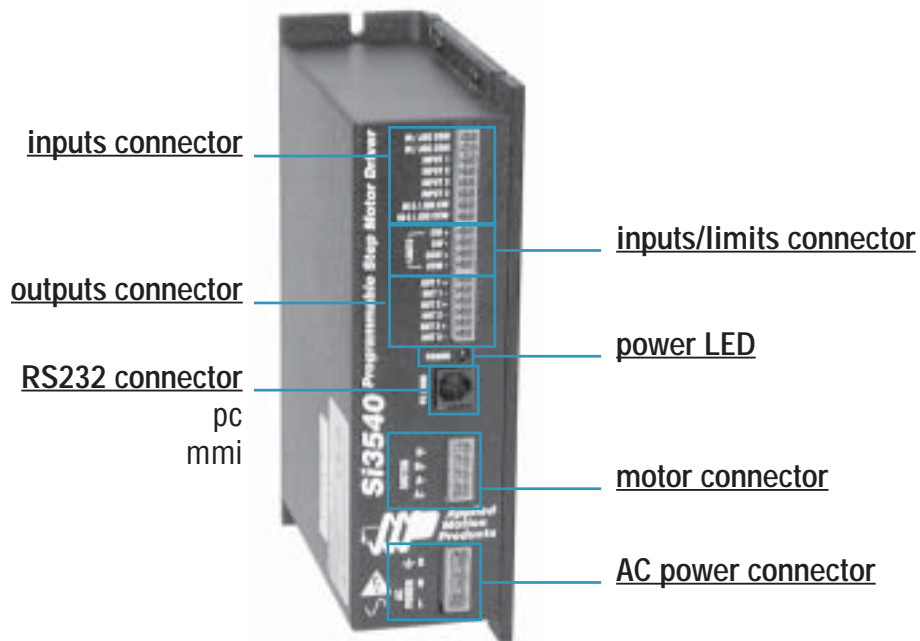

I/O		MOTOR	
position no.		position no.	
1	in/jog com	1	B-
2	in/jog com	2	B+
3	input 1	3	A-
4	input 2	4	B+
5	input 3		
6	input 4		
7	in 5/jog cw		
8	in 6/jog ccw		
			AC POWER
		position no.	
		1	G
		2	N
		3	L
LIMITS	9 CW+		
	10 CW-		
	11 CCW+		
	12 CCW-		
	13 out 1+		
	14 out 1-		
	15 out 2+		
	16 out 2-		
	17 out 3+		
	18 out 3-		

NEMA 11, 14, 17 Motor Data

RECOMMENDED MOTORS FOR Si3540						
FEATURES	11	11	14	17	17	17
Motor P/N:	11012	11013	14842	17068	17071	17075
Motor Current amps	1.00	1.00	1.00	1.34	1.70	1.70
Resistance Ohms	1.40	2.00	4.30	2.10	1.70	1.70
Holding Torque oz-in	7.4	15.3	26	31.4	51	62.6
Rotor Inertia oz-in ²	0.044	0.098	0.109	0.19	0.29	0.37
Bearings						
Thrust Load (lbs)	3.0	3.0	3.0	3.0	3.0	3.0
Radial Load (lbs)	5.0	5.0	5.0	5.0	5.0	5.0
Radial Play inch/lbs	.001 @ 1 lb	.001 @ 1 lb	.0004 max @ 1 lb	.0008 max @ 1 lb	.0008 max @ 1 lb	.0008 max @ 1 lb
End Play inch/lbs	.003 max @ 2 lbs.	.003 max @ 2 lbs.	.0004 max @ 2 lbs.	.003 max @ 2.2 lbs.	.003 max @ 2.2 lbs.	.003 max @ 2.2 lbs.
Weight lbs.	0.26	0.39	0.47	0.44	0.57	0.73

Motor current, resistance and torque ratings are with parallel connection

NEMA 11, 14, 17 Motor Dimensions

NEMA 11

Model	L
11012	1.32"
11013	1.87"

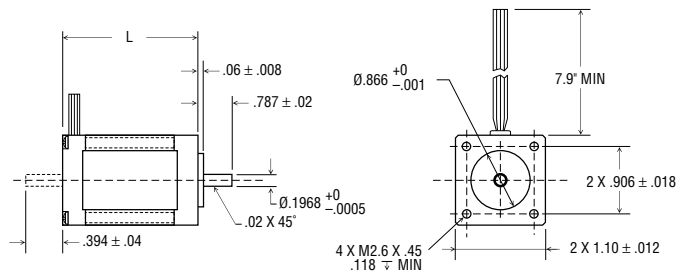

NEMA 14

Model	L
14842	1.57"

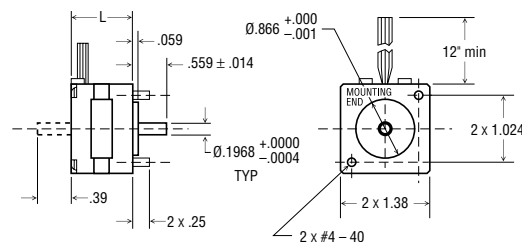

NEMA 17

Model	L
17068	1.30"
17071	1.54"
17075	1.85"

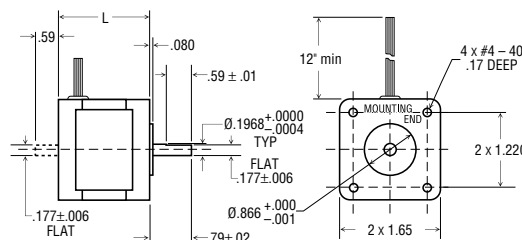

Torque Curves

Si3540 with NEMA 11, 14, 17 Step Motors

11012 MOTOR

Motor Connection: 4 Lead Bipolar
Drive Setting: Full, 1/10th Step • 1.0 A/Phase

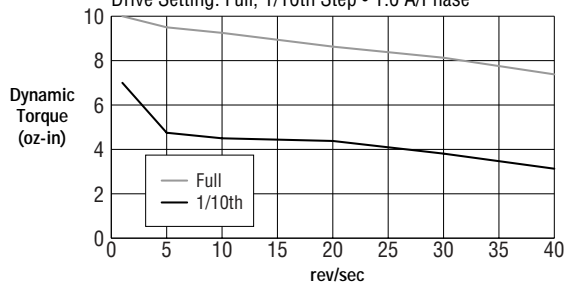

11013 MOTOR

Motor Connection: 4 Lead Bipolar
Drive Setting: Full, 1/10th Step • 1.0 A/Phase

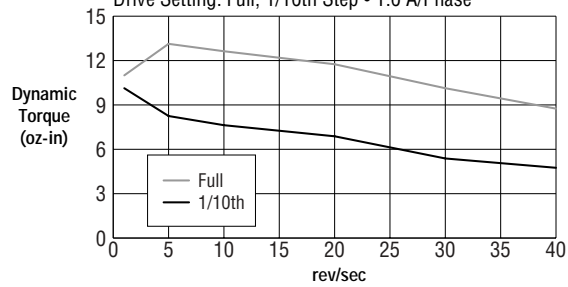

14842 MOTOR

Motor Connection: Parallel
Drive Setting: Full, 1/10th Step • 1.0 A/Phase

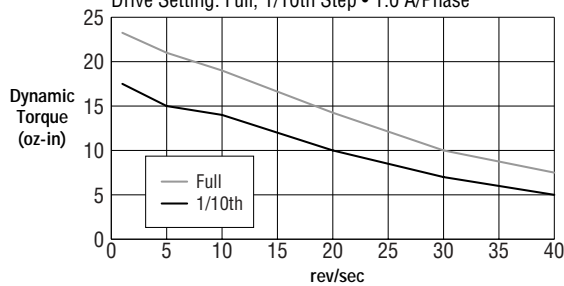

17068 MOTOR

Motor Connection: Parallel
Drive Setting: Full, 1/10th Step • 1.4 A/Phase

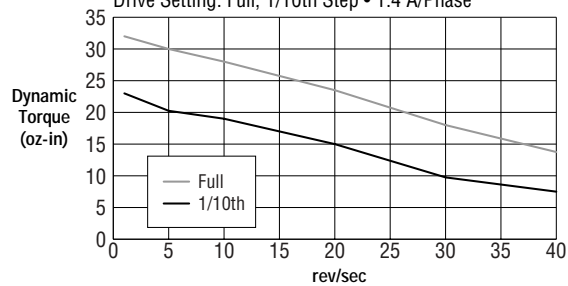

17071 MOTOR

Motor Connection: Parallel
Drive Setting: Full, 1/10th Step • 1.7 A/Phase

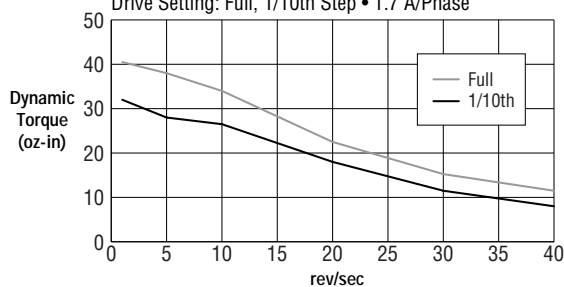

17075 MOTOR

Motor Connection: Parallel
Drive Setting: Full, 1/10th Step • 1.7 A/Phase

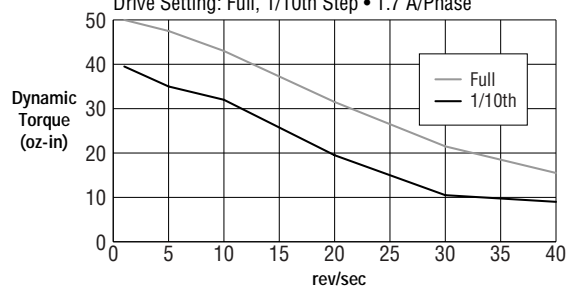

Torque Curves

Si3540 with NEMA 23 Step Motors

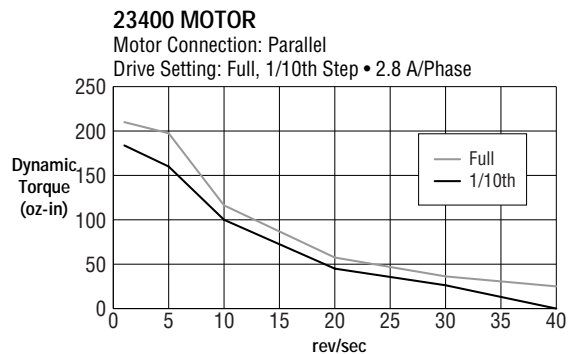
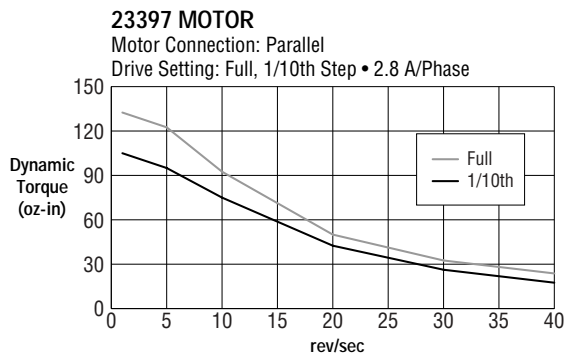
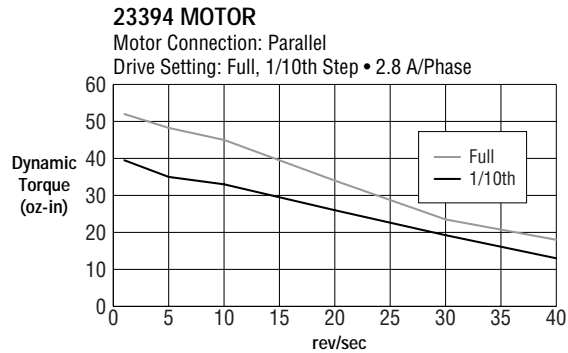
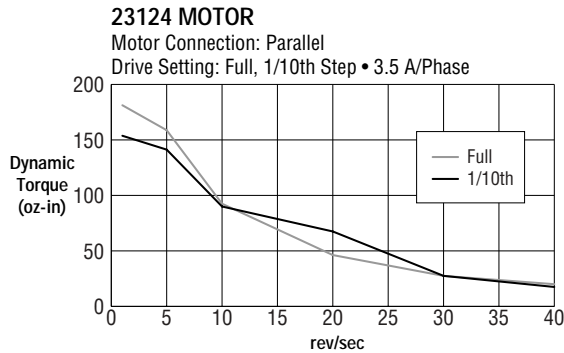
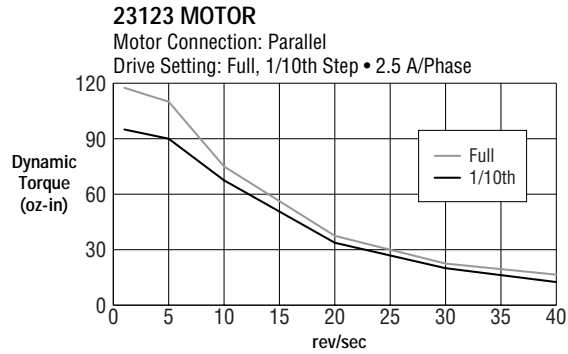
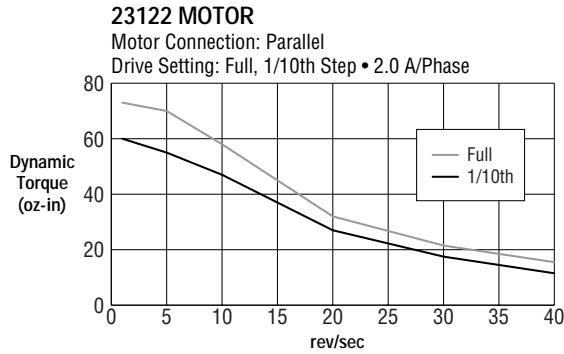

COMPLETE SYSTEM ORDERING

Drive Type	Motor System Number	Step Motor Description
PDO 3540	11012	NEMA 11 high torque one stack
Si3540	11013	NEMA 11 high torque two stack
	14842	NEMA 14 two stack
	17068	NEMA 17 high torque one stack
	17071	NEMA 17 high torque two stack
	17075	NEMA 17 high torque three stack
	23122	NEMA 23 one stack
	23123	NEMA 23 two stack
	23124	NEMA 23 three stack
	23394	NEMA 23 high torque one stack
	23397	NEMA 23 high torque two stack
	23400	NEMA 23 high torque three stack

System Ordering Example: Si3540 - 23122

DRIVE ONLY ORDERING

Drive Type	Description
PDO 3540	Packaged 3.5 amps, 40 VDC, 110/220 VAC input. Microstepping pulse & direction/oscillator drive.
Si3540	Packaged 3.5 amps, 40 VDC, 110/220 VAC input. Microstepping fully programmable drive/indexer with <i>Sj™</i> software.

OPTIONAL ACCESSORIES

Type	Description
MMI-01	Standard man-machine interface.
MMI-02	Man-machine interface with backlit display.