



# SureCross™ DX80 Wireless FlexPower™ Counter Node

Configurable FlexPower Node with 2 Selectable Counter Inputs, 2 Selectable Discrete Inputs, and 2 Discrete NMOS Outputs



## Features

The SureCross™ DX80 is a radio frequency network system built around a Gateway and one or more Nodes.

- Wireless industrial I/O device with two selectable discrete inputs, two selectable discrete pulse counter inputs, and two discrete (NMOS sinking) outputs
- User selectable 10 KHz event counter(s) and/or 25 KHz rate counter
- FlexPower™ power input options allow for +10 to 30V dc, solar, and battery power sources
- Frequency Hopping Spread Spectrum (FHSS) technology and Time Division Multiple Access (TDMA) control architecture combine to ensure reliable data delivery within the unlicensed Industrial, Scientific, and Medical (ISM) bands
- Transceivers provide two-way communication between the Gateway and Node, including fully acknowledged data transmission
- Lost RF links are detected and relevant outputs set to user-defined conditions
- External or internal antenna

For additional information and a complete list of accessories, including FCC approved antennas, please refer to Banner Engineering's website, [www.bannerengineering.com/surecross](http://www.bannerengineering.com/surecross).

## Models

Model	FlexPower™	Frequency	Antenna	I/O
DX80N9X2S4A2	+10 to 30V dc or 3.6 to 5.5V dc low power option	900 MHz ISM Band	External	Discrete Inputs: Two Selectable Discrete, Two Selectable Counter Discrete Outputs: Two Sinking NMOS
DX80N9X2W4A2			Internal	
DX80N2X2S4A2		2.4 GHz ISM Band	External	
DX80N2X2W4A2			Internal	

### WARNING . . . Not To Be Used for Personnel Protection

Never use these products as sensing devices for personnel protection. Doing so could lead to serious injury or death.

These devices do NOT include the self-checking redundant circuitry necessary to allow their use in personnel safety applications. A device failure or malfunction can cause either an energized or de-energized output condition. Consult your current Banner Safety Products catalog for safety products that meet OSHA, ANSI, and IEC standards for personnel protection.



# SureCross™ DX80 Wireless FlexPower™ Counter Node

## Hookup Diagrams

### Modbus Register Block

I/O Point*	Gateway Modbus Holding Register	Node Modbus Register	DX80** All Discrete I/O (Event and Rate Counter)	DX80 All Discrete I/O (Event Counters)	Terminal Block Label
1	1	1 + (Node# • 16)	Discrete IN 1	Discrete IN 1	DI1
2	2	2 + (Node# • 16)	Discrete IN 2	Discrete IN 2	DI2
3	3	3 + (Node# • 16)	Event Count IN 1 High Word	Event Count IN 1 High Word	CI1
4	4	4 + (Node# • 16)	Event Count IN 1 Low Word	Event Count IN 1 Low Word	CI1
5	5	5 + (Node# • 16)	Rate Counter	Event Count IN 2 High Word	CI2
6	6	6 + (Node# • 16)		Event Count IN 2 Low Word	CI2
7	7	7 + (Node# • 16)	Reserved	Reserved	
8	8	8 + (Node# • 16)	Device Message	Device Message	
9	9	9 + (Node# • 16)	Discrete OUT 1	Discrete OUT 1	DO1
10	10	10 + (Node# • 16)	Discrete OUT 2	Discrete OUT 2	DO2
11	11	11 + (Node# • 16)	Clear Counter 1	Clear Counter 1	
12	12	12 + (Node# • 16)			
13	13	13 + (Node# • 16)	Clear Counter 2	Clear Counter 2	
14	14	14 + (Node# • 16)			
15	15	15 + (Node# • 16)	Control Message	Control Message	
16	16	16 + (Node# • 16)	Reserved	Reserved	

\* These are the I/O points as displayed on the device LCD.

\*\* Default configuration

### Node I/O Terminal Block

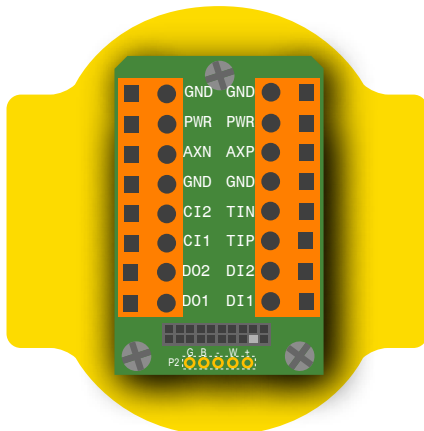

Wiring terminals AXN, AXP, TIN, and TIP are not used in this model. Do not make any wiring connections to these terminals.

### 5-pin M12 Euro Hookup



1	Brown	+10 to 30V dc Input
3	Blue	dc common (GND)
5	Gray	3.6 to 5.5V dc

Do not apply more than 5.5V dc to the gray wire.

### Sourcing Input Wiring

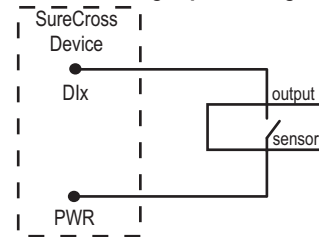

### Sinking Input Wiring

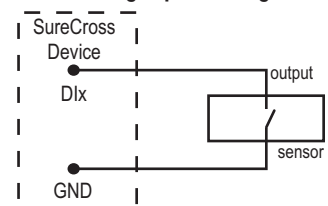

For additional information, including installation and setup, weatherproofing, device menu maps, troubleshooting, and a list of accessories, please refer to the DX80 Wireless Network product manual, Banner p/n 132607.

# SureCross™ DX80 Wireless FlexPower™ Counter Node

## Device Configuration

Device Settings	Switches							
	1	2	3	4	5	6	7	8
Rotary Switch Address Mode	OFF*							
Extended Address Mode	ON							
Discrete IN #1 NPN					OFF*			
Discrete IN #1 PNP					ON			
Discrete IN #2 NPN						OFF*		
Discrete IN #2 PNP						ON		
Counter 2 Rate							OFF*	
Counter 2 Event							ON	
Report Interval 16 seconds								OFF*
Report Interval 1 second								ON

\* Default configuration

The DX80 Pulse Counter uses DIP switches to configure the following parameters. After making any changes to the DIP switches, cycle power to the device to activate the changes.

### Address Mode

Extended addressing mode allows for specific Node to Gateway binding and allows network expansion for more than 16 devices in a wireless network. For most users, this switch is OFF. In Rotary Switch address mode, the left rotary dial establishes the network ID and the right rotary dial sets the device ID. The wireless network is restricted to a maximum of 16 devices.

For more information on extended address mode, refer to the SureCross™ Wireless I/O Network product manual.

### Discrete Inputs

Switches 5 and 6 select the discrete inputs characteristics; sinking (NPN) or sourcing (PNP).

### Counter Type

The **event counter** counts the total number of times an input signal changes state. The counter increments on the falling edge of an input signal when the signal level crosses the threshold. The count value is stored in EEPROM every hour. On power up this value is restored as the beginning count.

The **rate counter** calculates the frequency of the input signal, in Hz. By default the counter input is defined as a rate (frequency) counter. This input can be changed to an event counter using switch 7.

### Report Rate

The report rate defines how often the device reports counter inputs to the Gateway and is selectable using switch 8. For FlexPower™ applications, setting the report interval to 16 seconds extends the battery life.

# SureCross™ DX80 Wireless FlexPower™ Counter Node

## Counter Configuration

Counter Input 1	Switches			
	1	2	3	4
Low threshold (0.25V)	OFF*			
High threshold (1.5V)	ON			
Debounce enabled		OFF*		
Debounce disabled		ON		
Self-energized input (e.g. mag pickup)			OFF*	OFF*
Enable PNP (sourcing)			OFF	ON
Enable NPN (sinking)			ON	OFF

\* Default configuration

Counter Input 2	Switches			
	5	6	7	8
Debounce enabled	OFF*			
Debounce disabled	ON			
Self-energized input (e.g. mag pickup)		OFF*	OFF*	
Enable PNP (sourcing)		OFF	ON	
Enable NPN (sinking)		ON	OFF	
Low threshold (0.25V)				OFF*
High threshold (1.5V)				ON

\* Default configuration

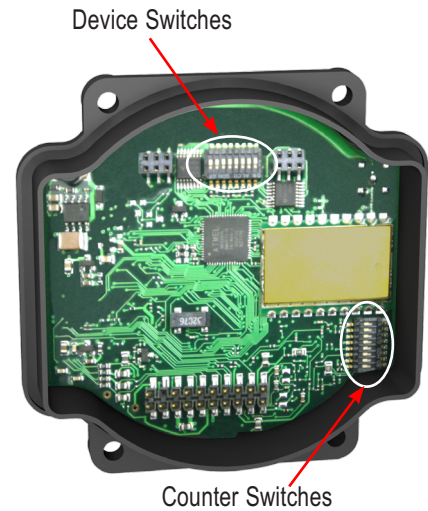

The counter input DIP switches define the characteristics of the counter inputs.

### Debounce

Debounce establishes how to examine a signal's transitions. The factory default setting is to activate the input filtering to compensate for unclean state transitions. To turn off the input filtering, set the switch to the ON position.

### Inputs

Counter switches 6 and 7 define the inputs as self-energized, sinking (NPN), or sourcing (PNP).

A self-energized input does not require pull-up or pull-down devices for proper operation. A magnetic pick-up is a self-energized input. The input threshold can be adjusted to compensate for low amplitude signals.

### Threshold

The counter has a selectable input threshold of 0.25V or 1.5V. For sinking (NPN) or sourcing (PNP) inputs, set the threshold to 1.5V.

# SureCross™ DX80 Wireless FlexPower™ Counter Node

## Event Counter Presets

The event counter input can be preset from the Node menu system or from a host system using Advanced Control Messages. The LCD menu system on the Node allows the user to preset event counter values on each available counter input. From the host system, each device has allocated Node registers 7, 15, and 16 that send preset data to the event counter. When power is applied to the Node, the counter value is reset to the last saved value. The counter value is saved every hour.

The event counter input is a 32-bit value that can be preset using the parameter control codes 143 (0x8F) and 144 (0x90). Parameter control code 143 writes the lower half [15:0] of the counter and code 144 writes the upper half [31:16] of the counter.

Select which counter to preset by defining the Counter Select Mask. The first bit position of the mask (bit 0, right justified) selects the first counter and the second bit position selected the second counter. Set the Node's register 16 to the high or low data value. Read Node register 7 for the transfer acknowledgement. Write to Node register 16 before writing to Node register 15.

There are 16 Modbus holding registers for each SureCross™ device. To calculate the registers for other Nodes, use this equation: Register number = I/O# + (Node # • 16). For example, the Gateway is always device 0 (or Node 0), so the Gateway's holding registers are registers 1 through 16. The registers for Node 1 are 17 through 32 and the registers for Node 2 are 33 through 48.

<b>Node Reg 16</b>	Low or High Value	
<b>Node Reg 15</b>	143 or 144 (0x8F or 0x90)	Counter Select Mask
<b>Node Reg 7</b>	Acknowledge Code 143 or 144	Acknowledge Counter Select Mask

**Example:** To preset Node 2's counter 2 to the value 20,567,001 (hex 0139 D3D9), follow these steps:

1. Write the upper word to the counter using control code 144 (0x90).

<b>Modbus Reg 48</b>	0139	
<b>Modbus Reg 47</b>	0x90	2
<b>Modbus Reg 39</b>	0x90	2

2. Write the lower word to the counter using control code 143 (0x8F).

<b>Modbus Reg 48</b>	D3D9	
<b>Modbus Reg 47</b>	0x8F	2
<b>Modbus Reg 39</b>	0x8F	2

The counter has been preset to 20,567,001 (0x0139 D3D9)

### Preset Using the Node's Menu System

To manually enter a counter preset, follow the LCD menu flow using the diagram shown.

1. Single click button 1 to move across the top level menus. Click button 1 until the display shows IOCFG.
2. Click button 2 to enter the I/O Configuration submenu structure.
3. Single click button 1 to move across the I/O points. Single click button 2 to enter the preset configuration for the desired I/O point. I/O 3 is the event counter and I/O 5 is the rate counter.
4. The screen displays the counter number, usually CNTR 1 or CNTR 2. Single click button 2 to move down the menu structure.
5. Use the right rotary switch to begin setting the counter preset. Digit selection begins with the least significant digit (the right-most digit). After selecting the least significant digit of the counter preset, single click button 1 to advance left to the next significant digit.
6. Use the right rotary switch to select the second digit. Single click button 1 to advance to the next digit.

# SureCross™ DX80 Wireless FlexPower™ Counter Node

## Event Counter Presets, Continued

7. When the counter preset has been entered, single click button 2 to save the value. The second screen of counter preset digits displays only when more than four digits are necessary. The preset counter may be set from zero to 4,000,000,000.
8. Double click button 2 to exit this menu. If you try to leave this menu without resetting the rotary switch back to its network address position, the menu system prompts you to correct the switch setting before returning to RUN mode. The prior network address setting displays.
9. Single click button 2 to enter the new network address. The new address is confirmed.
10. Single click button 2 to save the network address and return to the IOCFG menu and RUN mode.

## Clearing the Event Counter

### Clearing Counts

The counter Nodes have the ability to clear the counter values from a mapped input signal or from a host system writing to a Modbus register. For example, a push button on a Gateway can be mapped to Node register 11 to clear counter 1 when the button is pressed.

Reset the counter by writing a 1 to Node register 11 for counter 1 or Node register 13 for counter 2.

## Menu Structure

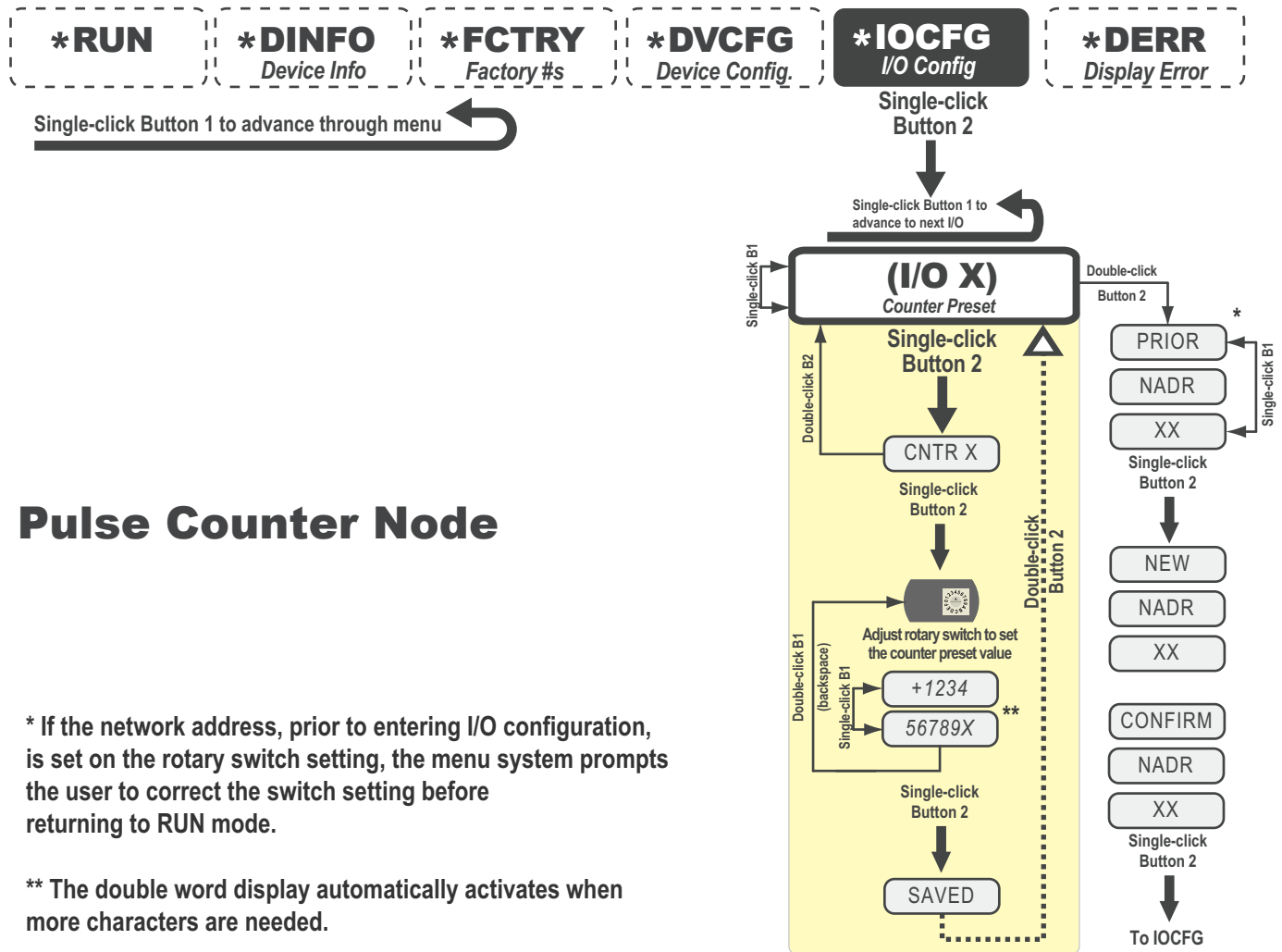

## Pulse Counter Node

\* If the network address, prior to entering I/O configuration, is set on the rotary switch setting, the menu system prompts the user to correct the switch setting before returning to RUN mode.

\*\* The double word display automatically activates when more characters are needed.

# SureCross™ DX80 Wireless FlexPower™ Counter Node

## Specifications

Many of the DX80 parameters are configurable. The values in the tables represent factory defaults unless otherwise noted.

Radio	900 MHz	2.4 GHz
Range, with standard 2 dB antenna*	Up to 4.8 kilometers (3 miles)	Up to 3.2 kilometers (2 miles)
Frequency	902 to 928 MHz ISM band	2.4 to 2.4835 GHz ISM Band
Transmit Power	21 dBm Conducted	18 dBm Conducted, ≤ 20 dBm EIRP
Spread Spectrum Technology	FHSS (Frequency Hopping Spread Spectrum)	FHSS (Frequency Hopping Spread Spectrum)
Antenna Connector	Ext. Reverse Polarity SMA, 50 Ohms	Ext. Reverse Polarity SMA, 50 Ohms
Antenna Max. Tightening Torque	0.45 N•m (4 in•lbf)	0.45 N•m (4 in•lbf)
Link Timeout	Defined by Gateway	Defined by Gateway



\* The range depends on the environment and line of sight. High-gain antennas are available to increase the range.

General	
Power*	+10 to 30V dc (For European applications: +10 to 24V dc, ± 10%)
Power Consumption	Less than 1.4 W (60 mA) at 24V dc
Mounting	#10 or M5 (M5 hardware included)
M5 Fasteners Max. Tightening Torque	0.56 N•m (5 in•lbf)
Case Material	Polycarbonate
Weight	0.26 kg (0.57 lb.)
Indicators	Two LED, bi-color
Switches	Two Push Buttons
Display	Six Character LCD
External Cable Glands	Four PG-7 type, One 1/2 NPT type
Cable Glands Max. Tightening Torque	0.56 N•m (5 in•lbf)
Inputs	
Discrete Inputs	Two Sinking
Discrete Input Rating	3 mA max current at 30V dc
Discrete Input Sample Rate	125 milliseconds
Discrete Input Report Rate	125 milliseconds
Discrete Input ON Condition (Sourcing)	Greater than 8V
Discrete Input OFF Condition (Sourcing)	Less than 5V
Discrete Input ON Condition (Sinking)	Less than 0.7V
Discrete Input OFF Condition (Sinking)	Greater than 2V or Open
Pulse Inputs	
Input Characteristics	Two Pulse Inputs (Sinking, Sourcing, Self-energized), DIP Switch Selectable
Input Thresholds	Programmable Threshold 1.5V, 0.25V (Sinking or sourcing selected inputs require the 1.5V threshold setting)
Input Debounce	DIP Switch Selectable. Enable debounce to filter a noisy input signal that may lead of false triggers
Event Input	Event pulse input rating 1 Hz to 10 KHz For battery powered devices, the recommended input rating is less than 1 KHz
Rate Input	1 to 25 KHz

\* For European applications, power the DX80 from a Limited Power Source as defined in EN 60950-1.

# SureCross™ DX80 Wireless FlexPower™ Counter Node

## Specifications, continued

<b>Outputs</b>	
<b>Discrete Outputs</b>	Two NMOS Sinking
<b>Discrete Output Rating</b>	Less than 10 mA max current at 30V, ON-State Saturation: Less than 0.7V at 20 mA
<b>Discrete Output Update Rate</b>	Up to 1 per second
<b>Discrete Output ON Condition</b>	Less than 0.7V
<b>Discrete Output OFF Condition</b>	Open
<b>Environmental</b>	
<b>Environmental Rating*</b>	IEC IP67; NEMA 6
<b>Operating Temperature**</b>	-40 to +85° C (Electronics); -20 to +80° C (LCD)
<b>Operating Humidity</b>	95% max. relative (non-condensing)
<b>Radiated Immunity</b>	10 V/m, 80-2700 MHz (EN61000-6-2)
<b>Shock and Vibration</b>	IEC 68-2-6 and IEC 68-2-7 <b>Shock:</b> 30g, 11 millisecond half sine wave, 18 shocks <b>Vibration:</b> 0.5 mm p-p, 10 to 60 Hz
<b>Compliance</b>	
<b>900 MHz Models</b>	FCC ID TGUDX80: This device complies with FCC Part 15, Subpart C, 15.247 IC: 7044A-DX8009 
<b>2.4 GHz Models</b>	FCC ID UE300DX80-2400: This device complies with FCC Part 15, Subpart C, 15.247 ETSI/EN: In accordance with EN 300 328: V1.7.1 (2006-05) IC: 7044A-DX8024 

\* Please refer to the SureCross™ DX80 Wireless Network product manual, Banner p/n 132607, for installation and waterproofing instructions.

\*\* Operating the devices at the maximum operating conditions for extended periods can shorten the life of the device.

It is Banner Engineering's intent to fully comply with all national and regional regulations regarding radio frequency emissions. Customers who want to re-export this product to a country other than that to which it was sold must ensure that the device is approved in the destination country. A list of approved countries appears in the SureCross DX80 Wireless Product Manual, in the Agency Certifications section. Consult with Banner Engineering if the destination country is not on this list.

The manufacturer does not take responsibility for the violation of any warning listed in this document.



### CAUTION . . .

Make no modifications to this product.

Any modifications to this product not expressly approved by Banner Engineering could void the user's authority to operate the product. Contact the Factory for more information.

Always use lightning arrestors/surge protection with all remote antenna systems to avoid invalidating the Banner Engineering Corp. warranty. No surge protector can absorb all lightning strikes. Do not touch the SureCross device or any equipment connected to the SureCross device during a thunderstorm.

**WARRANTY:** Banner Engineering Corp. warrants its products to be free from defects for one year. Banner Engineering Corp. will repair or replace, free of charge, any product of its manufacture found to be defective at the time it is returned to the factory during the warranty period. This warranty does not cover damage or liability for the improper application of Banner products. This warranty is in lieu of any other warranty either expressed or implied.

All specifications published in this document are subject to change. Banner reserves the right to modify the specifications of products, prior to their order, without notice. Banner Engineering reserves the right to update or change documentation at any time. For the most recent version of any documentation, please refer to our website: [www.bannerengineering.com](http://www.bannerengineering.com). © 2007 Banner Engineering Corp. All rights reserved.