



VLT® AutomationDrive

The modular VLT® AutomationDrive

VLT® AutomationDrive allows for mass production and factory testing of highly customised drives. Upgrades and options are plug-and-play easy.

Enclosure

The drive meets requirements for enclosure class IP 20/Chassis. Optional IP 21/NEMA 1, IP 55/NEMA 12, IP 54/NEMA 12 or IP 66/NEMA 4x.

Cold plate technology

Up to 15 kW the drives are built on a rock-solid aluminium base that is integrated with the back panel. This provides high mechanical stability, efficient cooling and the option of cold plate operation.

Display options

Danfoss Drives' removable Local Control Panel is now available in 28 languages. Six of these are built-in (including Chinese), two of the languages can be changed by the user. The info button makes the printed manual virtually redundant. Users have been involved throughout the development to ensure great functionality and performance. The user group has significantly influenced design and function of the Local Control Panel. The Automatic Motor Adaptation, Quick Set-Up menu and large graphic display make commissioning and operation a breeze. Your choice of numerical display, graphical display or blind cover.

Modular Construction and Ease of Maintenance

All components are easily accessible from the front of the drive allowing for ease of maintenance and side-by-side mounting of drives. The drive is designed with a modular approach allowing for the easy replacement of modular sub-assemblies.

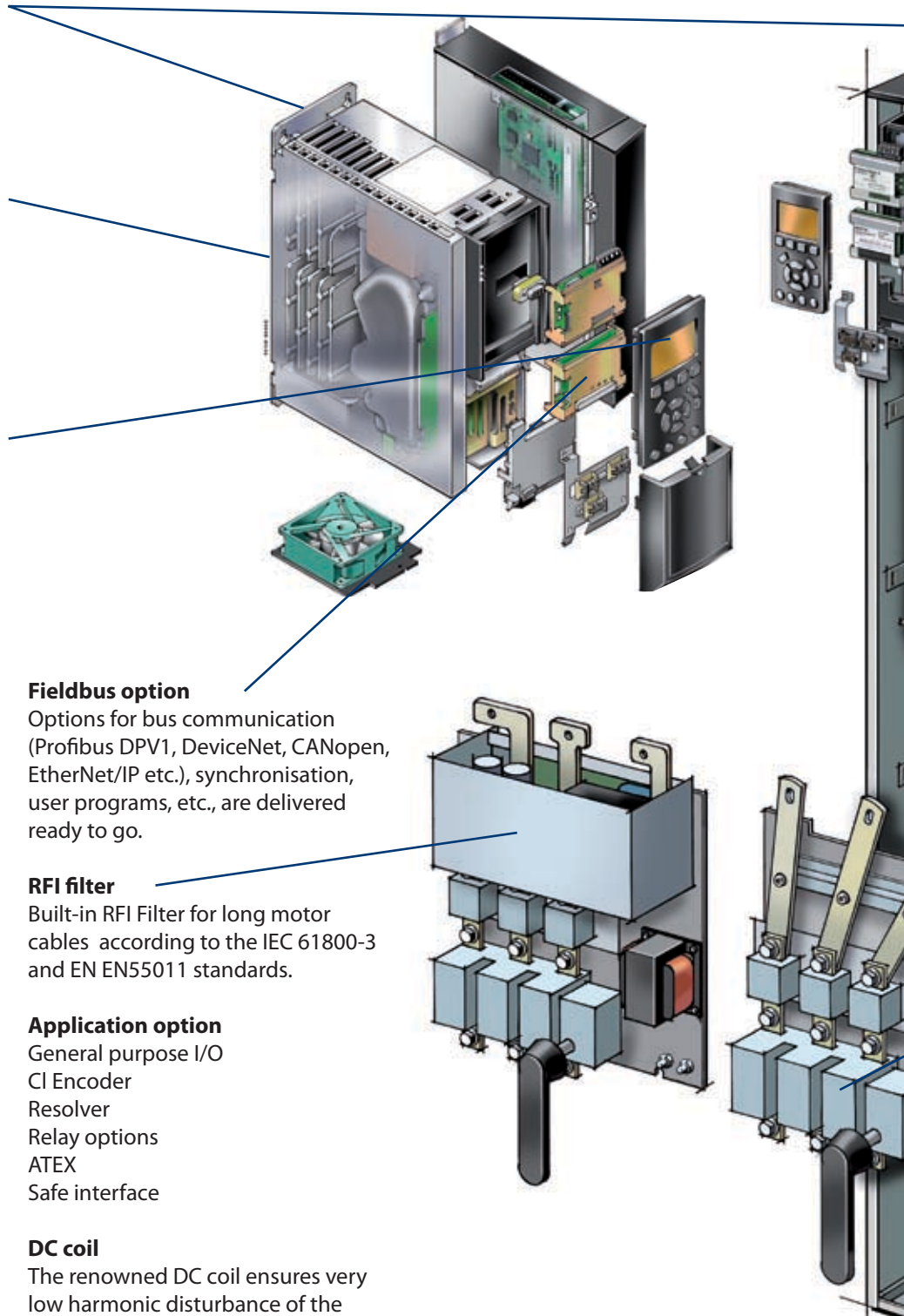

Fieldbus option

Options for bus communication (Profibus DPV1, DeviceNet, CANopen, EtherNet/IP etc.), synchronisation, user programs, etc., are delivered ready to go.

RFI filter

Built-in RFI Filter for long motor cables according to the IEC 61800-3 and EN EN55011 standards.

Application option

General purpose I/O
CI Encoder
Resolver
Relay options
ATEX
Safe interface

DC coil

The renowned DC coil ensures very low harmonic disturbance of the power supply, in accordance with IEC-1000-3-2. Compact design means no need for external modules.



Danfoss Drives received the Frost & Sullivan Award for Product Innovation 2006 for the unique VLT® AutomationDrive series.

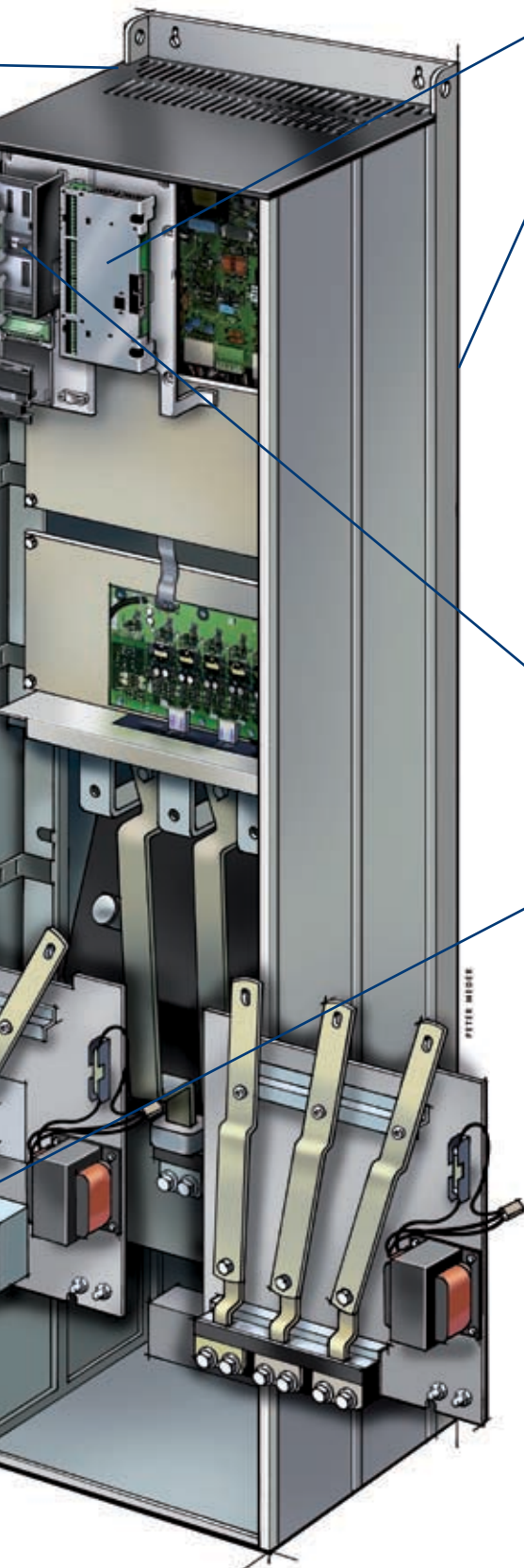

Programmable option

Free programmable option MCO 305 option for synchronisation, positioning, cam control, center winding and more.

Back Channel Cooling

A unique design uses a ducted back channel to pass cooling-air over heat sinks. This allows 85% of the heat losses to be exhausted directly outside of the enclosure with minimal air passing through the electronics area. This dramatically reduces temperature rise and contamination of the electronic components, improving reliability and prolonging life. There is an IP 54 seal between the back channel cooling duct and the electronics area of the drive.

Hot-pluggable LCP

The local control panel (LCP) can be plugged in or unplugged during operation. Settings are easily transferred via the control panel from one drive to another or from a PC with MCT10 set-up software.

Input mains option

Various input plate configurations are available including fuses, mains switch (disconnect), or RFI filter. Input plates are field adaptable if options need to be added after the installation.

Corrosive resistant

As an option, the back channel cooling duct work and heat sinks can be ordered with corrosion protection for installations in harsh environments, such as in salt-air environments near the ocean.

Control terminals

Specially developed spring-loaded cage clamps enhance reliability and facilitate easy commissioning and service.

50° C ambient temperature

The drive is designed to give maximum output at ambient temperatures up to 50° C.

Removable fan

Like most of the elements, the fan can be quickly removed and remounted for easy cleaning.

Safety

The VLT® AutomationDrive FC 302 comes standard with the safe stop functionality. The solution is approved by authorities for category 3 installations in accordance with EN 954-1 and SIL2/IEC 61508.

This feature prevents the drive from starting unintended. Enhanced safety features are available as options.

24 V

24 V supply keeps the VLT® AutomationDrive logic "alive" when the AC mains is removed.

Conformal coating

The electronic components are as standard coated as per IEC 60721-3-3, class 3C2. For harsh and aggressive environments, coating as per IEC 60721-3-3, class 3C3 is available.



Coated control boards are available for harsh environments.

Just one drive to run a complete production line

The VLT® AutomationDrive FC 300 is a single drive concept that controls all operations from standard to servo motors on any machine or production line. The standard versions cover a wide range of functions such as PLC functionality, automatic fine-tuning of motor control and self-analysis of performance.

Positioning, synchronising, and even servo performance are available too. All versions share an identical user interface, so once you've operated one drive you can use them all.

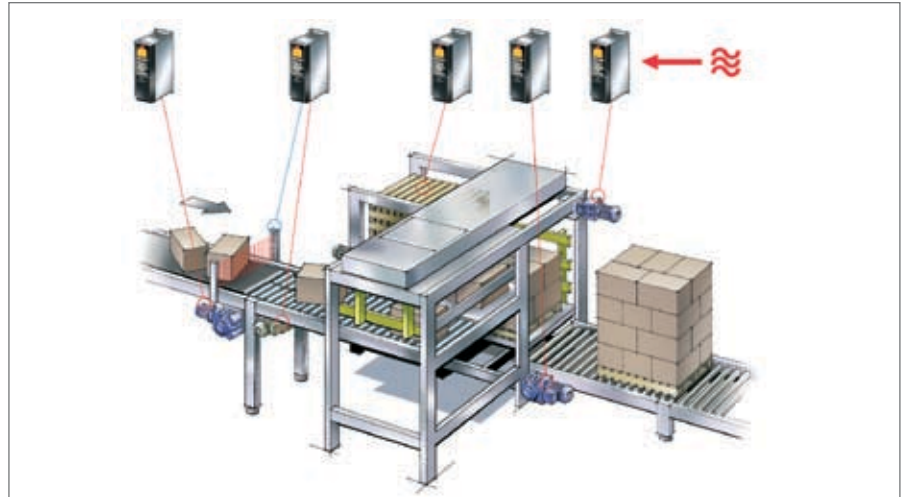

Add flexibility to precision

The new VLT® AutomationDrive lets you alter production speed without rebuilding the conveyor. The Precise Pulse Stop feature ensures that products always are where they should be on the line.

Speed or slow the entire line

Production speed can be changed at any time, even if the application involves several sections. The Precise

Pulse Reference feature makes the conveyors follow the encoder from master conveyor or virtual master drive, ensuring that all conveyors are in sync.

Benefits:

- The conveyor can be stopped at a precise location using an open loop system independent of production speed.

- Precise Pulse Stop compensates for the speed of the object when it passes the stop sensor. This results in a precise stop, regardless of production speed.

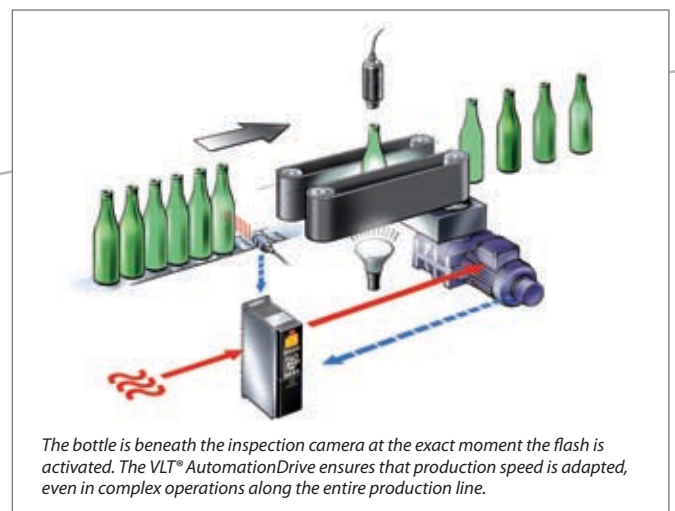
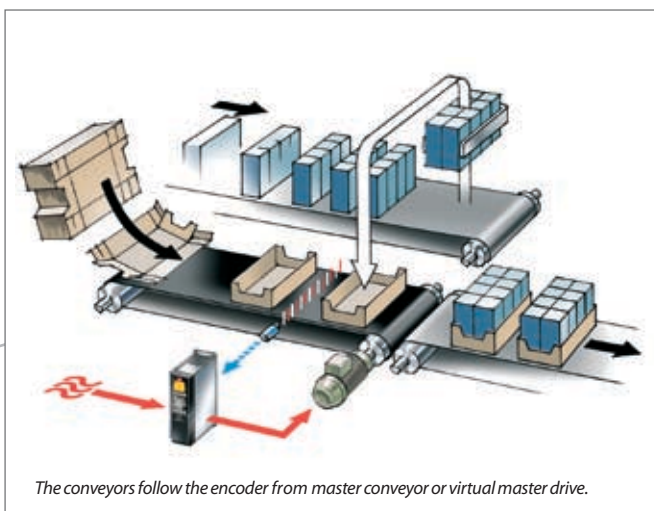

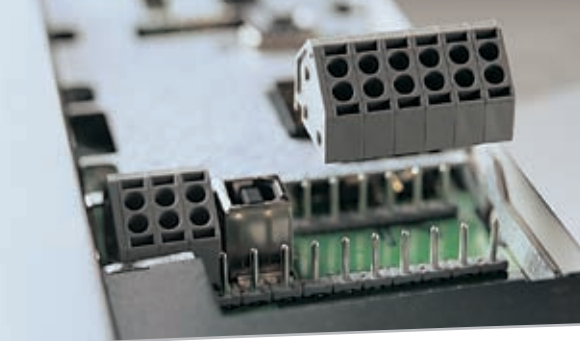

To disconnect wires, simply unplug the terminal blocks.



Plug-and-play is the way with the VLT® AutomationDrive. Even the power supply, sensor cables and looping connections are easy to use plugs.



The fieldbus option ready to plug in beneath the front panel. It can be turned upside down if you prefer to have the cable on top.

Built-in Smart Logic Controller

The Smart Logic Controller is a simple but clever way to keep your drive, motor and application working together. The controller monitors a specified event. When an event occurs, the controller triggers a specified act and starts monitoring the next event continuing for up to 20 steps before returning to step one.

The Smart Logic Controller is able to monitor any parameter that can be defined as “true” or “false”. This includes digital commands but

also logic expressions, allowing even sensor outputs to influence the operation. Temperature, pressure, torque, flow, time, load, frequency, voltage and other parameters combined with the operators “>”, “<”, “=”, “and” and “or” forms logical statements.

That’s why Danfoss calls it a “logic” controller. And it is why you can program the controller to react to almost any event you choose.

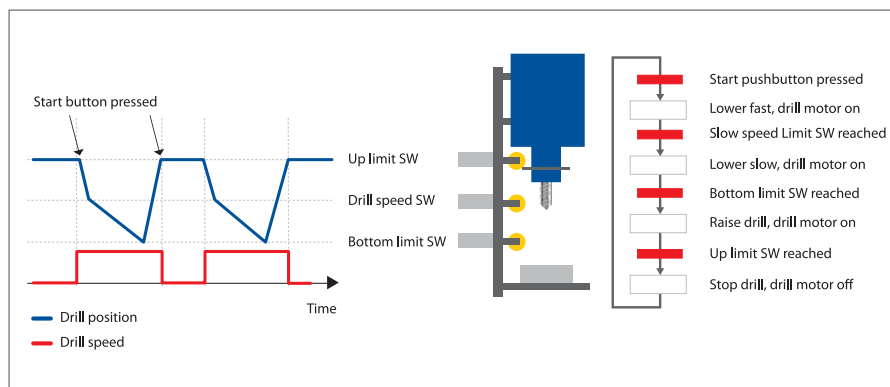
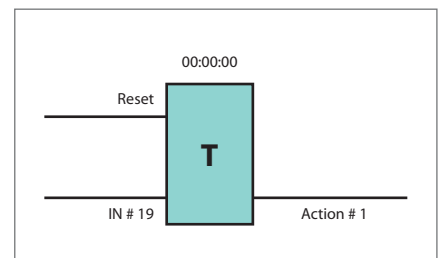
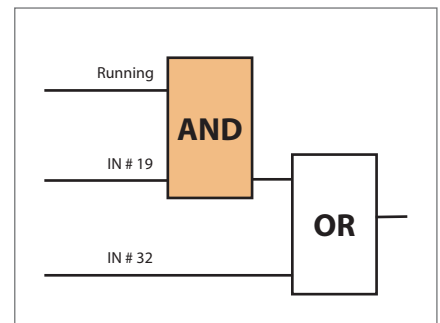
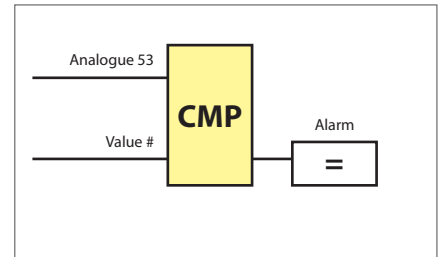

VLT® Motion Control Option

The Motion Control Option MCO 305 is an integrated programmable Motion Controller. It adds even more functionality and flexibility to the drives.

With the Motion Control Option, the VLT® AutomationDrive becomes an intelligent drive featuring highly accurate, dynamic motion control, synchronisation (electronic shaft), positioning and electronic Cam control.

Programmability lets you implement a variety of application functions, such as monitoring and intelligent error handling.

Dedicated options

VLT® Synchronizing Controller, VLT® Positioning Controller and VLT® Center Winder are pre-programmed for these specific tasks.

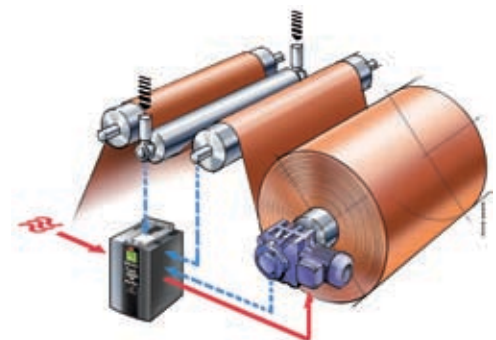

Award-winning control panel

Graphical display

- International letters and signs
- Showing bars and graphs
- Easy overview
- Possible to select 28 languages
- iF awarded design

Other benefits

- Removable during operation
- Up- and download functionality
- IP 65 rating when mounted in a panel door
- Up to 5 different variables visible at a time
- Manual speed/torque setting

Illumination

- Relevant buttons are illuminated when active



Menu structure

- Based on the well known matrix system in today's VLT® drives
- Easy shortcuts for the experienced user
- Edit and operate in different setups simultaneously

Quick Menus

- A Danfoss defined Quick Menu
- A Personal defined Quick Menu
- A Changes Made Menu lists the parameters unique for your application
- A Function Setup menu provides quick and easy setup for specific applications
- A Logging menu provides access to operation history

New buttons

- Info ("on board manual")
- Cancel ("undo")
- Alarm log (quick access)



LCP Panel mounting kit

The kit lets you mount the LCP in a IP 65 cabinet front.

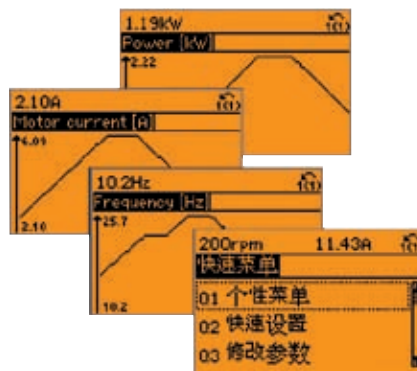

design award
winner

The VLT® AutomationDrive has an award-winning Local Control Panel and a well structured menu system that ensures fast commissioning and trouble-free operation of the many powerful functions.



Three panel options: graphical, numerical, blind cover.



The VLT® AutomationDrive is controlled locally via a control panel. This is plugged in directly or connected via a cable.



The VLT® AutomationDrive can be remote commissioned and monitored via a USB cable or fieldbus communication. Special software is available: Wizards, Data transfer tool, VLT® Set-up Software, MCT 10 and Language changer.

Intelligent heat management

Cooling can take place in various ways for different benefits

Total separation between cooling air and electronics allows for solutions where heat is removed outside cabinets.

With VLT® AutomationDrive, a flanged heat sink kit is available for mounting the drive in the backplate of a cabinet.



Panel Through Mounting

Forced convection cooling

A fan blows cold air through the cooling ribs of the aluminium base. The channel is easily cleaned without touching electronics.

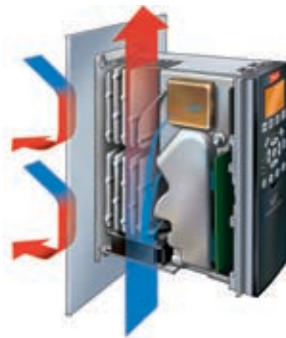

Wall mounted with forced cooling through the heat sink.

Cold plate cooling

External cooling is possible through the back side of the aluminium base.

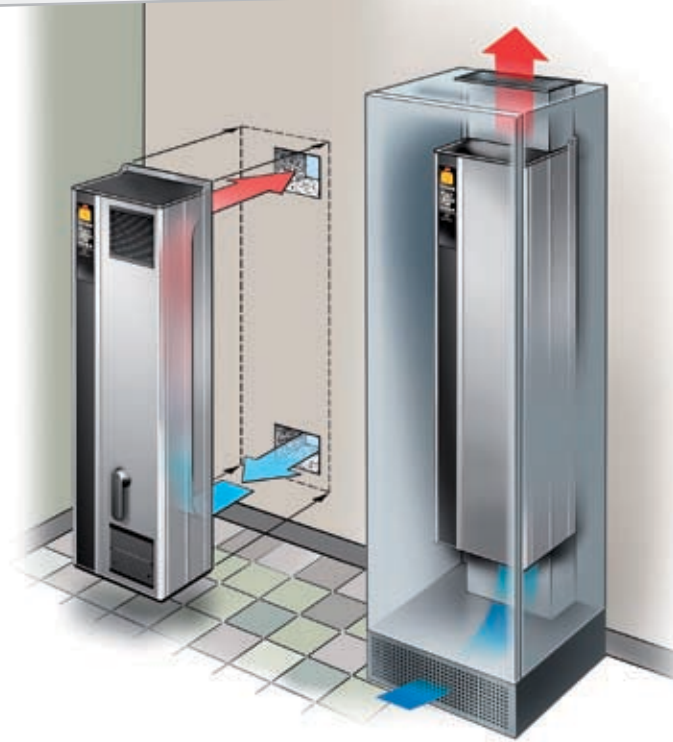

Innovative design reduces the risk of contaminants entering the drive and the panel and ensures a long life of the drives. With the duct cooling kit excess heat can be ventilated outside the control room – and outside the building. The need for additional air conditioning components and the energy consumption of these components is limited.

A smart, dedicated kit allows D3 and D4 enclosures to be mounted in Rittal cabinets so cool air removes 85% of excess heat without contact to the electronics.

Small footprint

VLT® AutomationDrive has a compact design. All power sizes are smaller than their predecessors. No dimension has increased and volumes are typically 20% smaller. Even though the drives can still be mounted “side by side” with 0 mm clearance.

Conversion kit

A conversion kit is available to facilitate exchange from earlier VLT® drives. The backplate has pre-drilled holes. Cabling from VLT® 5000 can be reused with the terminal adapter.



Reliable, accurate load handling

The VLT® AutomationDrive estimates motor currents generated by actual loads and compensates to make the crane start and stop smoothly just where it should. The same benefits apply to hoists and elevators.

Gentle on goods – and brakes

When stopped, the VLT® AutomationDrive will slow the hoist to zero before activating the mechanical brake. This results in gentler handling and virtually eliminates wear on the brakes.

Benefits:

- Low torque ripple gives smooth operation.
- Full holding torque capability at 0 RPM gives a smooth ride and reduces mechanical wear on gears and brakes – less maintenance and more production uptime.

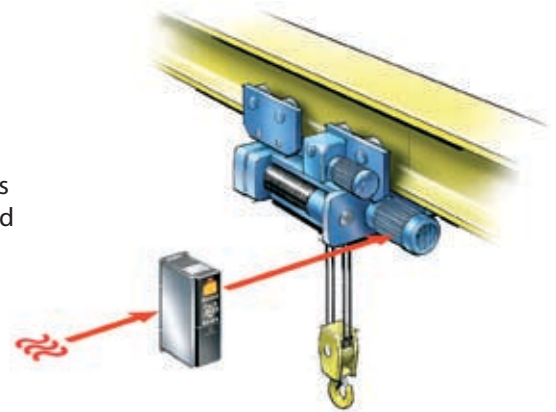

Kinetic backup

The VLT® AutomationDrive can utilise power generated from the kinetic energy for controlled ramp-down in case of power loss. The application is ready for quick restart when the power returns.

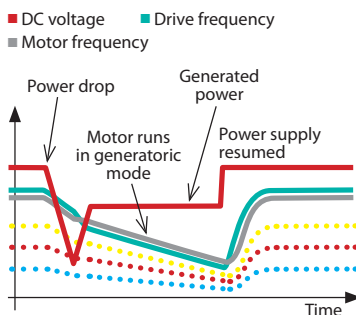

IP 55 for harsh environments IP 66 for wash down areas

All VLT® AutomationDrive versions have manganic phosphor rear bodies. The back of IP 66 is dip-coated with epoxy or polyester spray finish (60-100 µm). The cover is powder coated (80-100 µm).

The silicone gasket is tested with different detergents so the drives withstand the harsh cleaning agents in the food & beverage industry.

The IP 66 enclosed drives are suited for installation outdoor and in wash-down areas.



Accessories

Dynamic braking

The VLT® AutomationDrive can be ordered with a built-in dynamic brake option utilising the latest IGBT technology to provide fast deceleration of the connected motor. The dynamic brake option is a configurable option built into the VLT® AutomationDrive without the need of extra mounting space.

Brake resistor(s) can be used in conjunction with the dynamic brake to dissipate the heat/power regenerated by the motor during deceleration or overhauling load. Danfoss provides a large selection of different brake resistor types suitable for your application. Brake resistors must be ordered separately and field installed by the customer.



Advanced harmonic filters

VLT® Harmonic Filter AHF 010/005. AHF 010 reduces the harmonic current to less than 10%, while the AHF 005 lowers this current to less than 5%.

The Danfoss AHF 005 and AHF 010 are advanced harmonic filters and should not be compared with traditional harmonic trap filters. They have been specially designed to match the Danfoss frequency drives.

Disconnect switch available

Mounting the optional disconnect switch on the front of B, C, D or E enclosures eliminates the need for an external switch-box.



Sinewave filters

When the speed of a motor is controlled by a drive, resonance noise from the motor can occur. This is due to the design of the motor and the switching of IGBTs. The resonance frequency will correspond to the switching frequency of the drive.

In applications where this noise is undesirable, Danfoss offers Sinewave filters for the VLT® AutomationDrive to dampen the acoustics.

These filters are installed electrically between the VLT® AutomationDrive and motor to reduce

voltage rise time (dU/dt), peak voltage (V_{max}) and the ripple current to the motor, thus reducing the noise generated. Sinewave filters must be ordered separately and field installed by the customer.

dU/dt filters

dU/dt filters reduce the dU/dt values on the motor terminal phase-to-phase voltage – an issue that is important for short motor cables.

The phase-to-phase voltage is still pulse shaped. dU/dt filters prolong the lifetime of the motor.

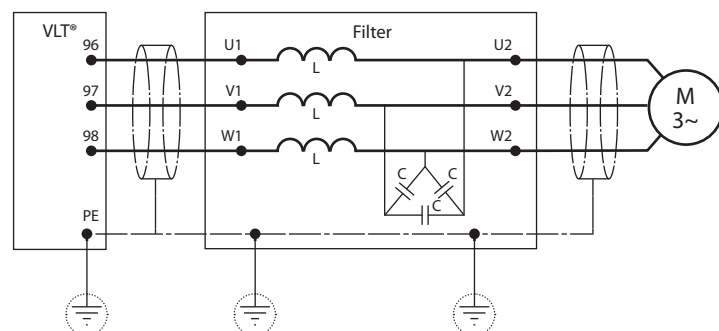

One drive – two performance levels

Special needs require special features and performance

	FC 301 A1*	FC 301	FC 302
Power range 200 – 240 V [kW]	0.25 – 1.5	0.25 – 37	0.37 – 45
Power range 380 – (480) 500 V [kW]	0.37 – 1.5	0.37 – 75	0.37 – 1.1 M
Power range 550 – 600 V [kW]	–	–	0.75 – 7.5
Power range 525 – 690 V [kW]	–	–	11 – 1.2 M
Amb. temp °C Avg.24 hours (IP 21) w/o de-rating	45	45	45
Ambient temp °C max (IP21) w/o de-rating	50	50	50
Ambient temp °C max with de-rating	55	55	55
IP 21/NEMA type1/IP 55/NEMA type12	√	√	√
IP 66/NEMA type 4x	–	√	√
Smart Logic Control	√	√	√
Logic Rule Control	√	√	√
Safe Stop input function approved	√	–	√
Local Control Panel numerical or graphical	√	√	√
Info/Help function	√	√	√
Personal menu (macro)	√	√	√
Regional settings (US mode)	√	√	√
Language settings	√	√	√
Change made restore previous setting	√	√	√
Password protection	√	√	√
Analogue input	0 to +10 V	0 to +10 V	-10 to +10 V
Digital inputs	5	5	6
Digital transistor outputs ¹⁾	1	1	2
Relay outputs	1	1	2
Analogue output resolution	12 bit	12 bit	12 bit
PC connection: RS 485 and USB	√	√	√
Default motor data	√	√	√
Permanent Magnet Motor algorithm	–	–	√
Process PID control	√	√	√
Precise Start/Stop	√	√	√
Preset references	8	8	8
Digipotmeter	√	√	√
Ramp functions: linear and S-ramps	√	√	√
Profibus, DeviceNet, CANOpen, EtherNet IP	√	√	√
Interface options:			
Extended input/outputs MCB 101	√	√	√
Encoders option MCB 102	√	√	√
Resolver option MCB 103	√	√	√
Relay option MCB 105	√	√	√
Safe PLC interface MCB 108	√	–	√
Motion Control Options: MCO 305	–	√	√
External 24 V back-up option MCB 107	–	√	√
Cable length – screened/unscreened	25/50 m	50/75 m	150/300 m
RFI EN55011 cl A1 (Industry)	<25 m	<50 m	<150 m
RFI EN55011 cl B (Domestic)	2.5 m	<10 m	<50 m
Voltage Vector Control VVC+	√	√	√
Flux Vector Control	–	–	√
Automatic Energy Optimizing (AEO)	–	√	√
Controlled ramp down	–	√	√
Flying start – catch spinning motor	–	√	√
Variable switching frequency 1.5 – 16 kHz ²⁾	1.5 – 10 kHz	√	√
Over Voltage Control	√	√	√
Fan replaceable	√	√	√

1) Converting digital inputs

2) Power-size dependent

* Smallest cabinet size

VLT® AutomationDrive FC 302 offers a wide range of advanced features

One wire safety



The VLT® AutomationDrive FC 302 comes standard with safe stop functionality suitable for category 3 installations as defined by EN 954-1 and SIL 2/IEC 61508. This feature prevents a drive from starting accidentally. This is crucial for applications where preventing unintended starts are of vital importance. The FC 302 terminal

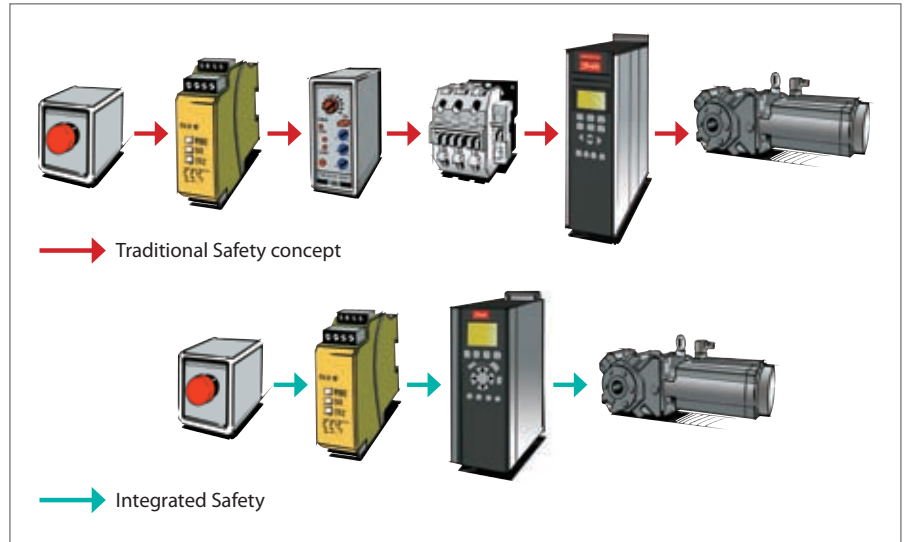

37 can be used as “safe coast” for this purpose – the stop function satisfies stop category 0 EN 60204-1. Expensive and bulky external components can be omitted, wiring simplified, and down-time minimised with this solution. And the safety signals can be transferred via discrete signals wiring (in compact machinery) or safe bus communication (in extended manufacturing plants). The coupling

of Pilz safety relay and VLT® AutomationDrive is perfect to obtain safe stop cat. 1, because VLT® AutomationDrive is approved for safety category 3 applications. The electrical connection is extremely simple – just one wire. VLT® AutomationDrive is approved for providing safe stop in category 3 installations without the need for feedback signals from the drive to the safety relay.

When torque is the issue

In all winders the torque required to accelerate and decelerate an application varies with the load. With centre winders the required torque even varies with the dimension of the roll. Torque mode with a high-precision torque control is needed.

It is essential in winding operations to fully control the tension of the material being wound. To maintain tangential tension independently of the line speed and roll diameter, the drive is able to dynamically follow a wide range of torque references.

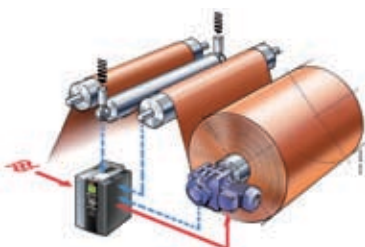

600 & 690 V

VLT® AutomationDrive FC302 comes in 600 and 690 V series specially relevant for heavy industries like chemistry, water and gas supply, mining, and forestry. 690 V versions are planned from 11 kW up to 1.2 MW.

Encoder check

The drive will automatically check and verify if the encoder is malfunctioning.

The feedback from the encoder is compared with a calculated speed.

VLT® AutomationDrive FC 302 runs permanent magnet motors

VLT® AutomationDrive FC 302 exploits full potential of permanent magnet motors in high dynamic applications.

Fast processors enable it to precisely control position, acceleration and torque.

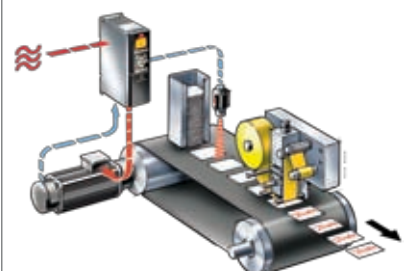

Specifications

Mains supply (L1, L2, L3)	FC 301	FC 302
Supply voltage	200-240 V ±10%	
Supply voltage	380-480 V	380-500 V ±10%
Supply voltage		550-600 V ±10%
Supply voltage		525-690 V ±10%
Supply frequency	50/60 Hz	
Displacement power factor (cos φ) near unity	(> 0.98)	
Switching on input supply L1, L2, L3	2 times/min.	

Output data (U, V, W)	FC 301	FC 302
Output voltage	0-100% of supply voltage	
Output frequency	0.2-1000 Hz	0-1000 Hz
Switching on output	Unlimited	
Ramp times	0.02-3600 sec.	
Closed loop	0-132 Hz	

Digital inputs	FC 301	FC 302
Programmable digital inputs	4(5) > 5	4(6) > 6
Logic	PNP or NPN	
Voltage level	0 - 24 V DC	
Voltage level, logic	'0' PNP logic < 5 V DC	
Voltage level, logic	'1' PNP logic > 10 V DC	
Voltage level, logic	'0' NPN logic > 19 V DC	
Voltage level, logic	'1' NPN logic < 14 V DC	
Maximum voltage on input	28 V DC	
Input resistance, Ri	Approx. 4 k Ω	
Scan interval	5 ms	1 ms

Analogue inputs		
Analogue inputs	2	
Modes	Voltage or current	
Voltage level	0 to +10 V	-10 to +10 V (scaleable)
Current level	0/4 to 20 mA (scaleable)	
Accuracy of analogue inputs	Max. error: 0.5% of full scale	

Pulse/encoder inputs	
Programmable pulse/encoder inputs	2/1
Voltage level	0 - 24 V DC (PNP positive logic)
Pulse input accuracy (0.1 - 110 kHz)	Max. error: 0.1% of full scale
Encoder input accuracy (1 - 110 kHz)	Max. error: 0.05% of full scale 32 (A), 33 (B) and 18 (Z)

Digital output	FC 301	FC 302
Programmable digital/pulse outputs	1	2
Voltage level at digital/frequency output	0 - 24 V DC	
Max. output current (sink or source)	40 mA	
Maximum output frequency at frequency output	32 kHz	
Accuracy on frequency output	Max. error: 0.1% of full scale	

Analogue output	FC 301	FC 302
Programmable analogue outputs	1	
Current range at analogue output	0/4 - 20 mA	
Max. load to common at analogue output	500 Ω	
Accuracy on analogue output	Max. error: 1% of full scale	

Onboard power supply	FC 301	FC 302
Output voltage	10.5 V ±0.5 V	
Max. load (10 V)	15 mA	
Max. load (24 V)	130 mA	200 mA

Relay output	FC 301	FC 302
Programmable relay outputs	1	2
Max. terminal load (AC) on 1-3 (break), 1-2 (make), 4-6 (break) power card	240 V AC, 2 A	
Max. terminal load (AC) on 4-5 (make) power card	400 V AC, 2 A	
Min. terminal load on 1-3 (break), 1-2 (make), 4-6 (break), 4-5 (make) power card	24 V DC 10 mA, 24 V AC 100 mA	

Cable lengths	FC 301	FC 302
Max. motor cable length, screened (shielded)	50 m	150 m
Max. motor cable length, unscreened (unshielded)	75 m	300 m

Surroundings/external	FC 301	FC 302
Enclosure	IP20/IP21/IP55/IP66	
Vibration test	0.7 g	
Max. relative humidity	5% - 95% (IEC 721-3-3; Class 3K3 (non-condensing) during operation)	
Aggressive environment (IEC 721-3-3)	Uncoated class 3C2	
Aggressive environment (IEC 721-3-3),	Coated class 3C3	
Ambient temperature	Max. 50 °C	

Protection mode for longest possible up-time	
<ul style="list-style-type: none"> Electronic thermal motor protection against overload Temperature monitoring of the heat sink ensures that the FC 300 cuts out if the temperature reaches 100 °C The FC 300 is protected against short-circuits on motor terminals U, V, W Protection against mains phase loss The FC 300 is protected against earth fault on motor terminals U, V, W 	



Global Marine

Connection examples

This diagram shows a typical installation of the VLT® AutomationDrive FC 300. The numbers represent the terminals on the drive.

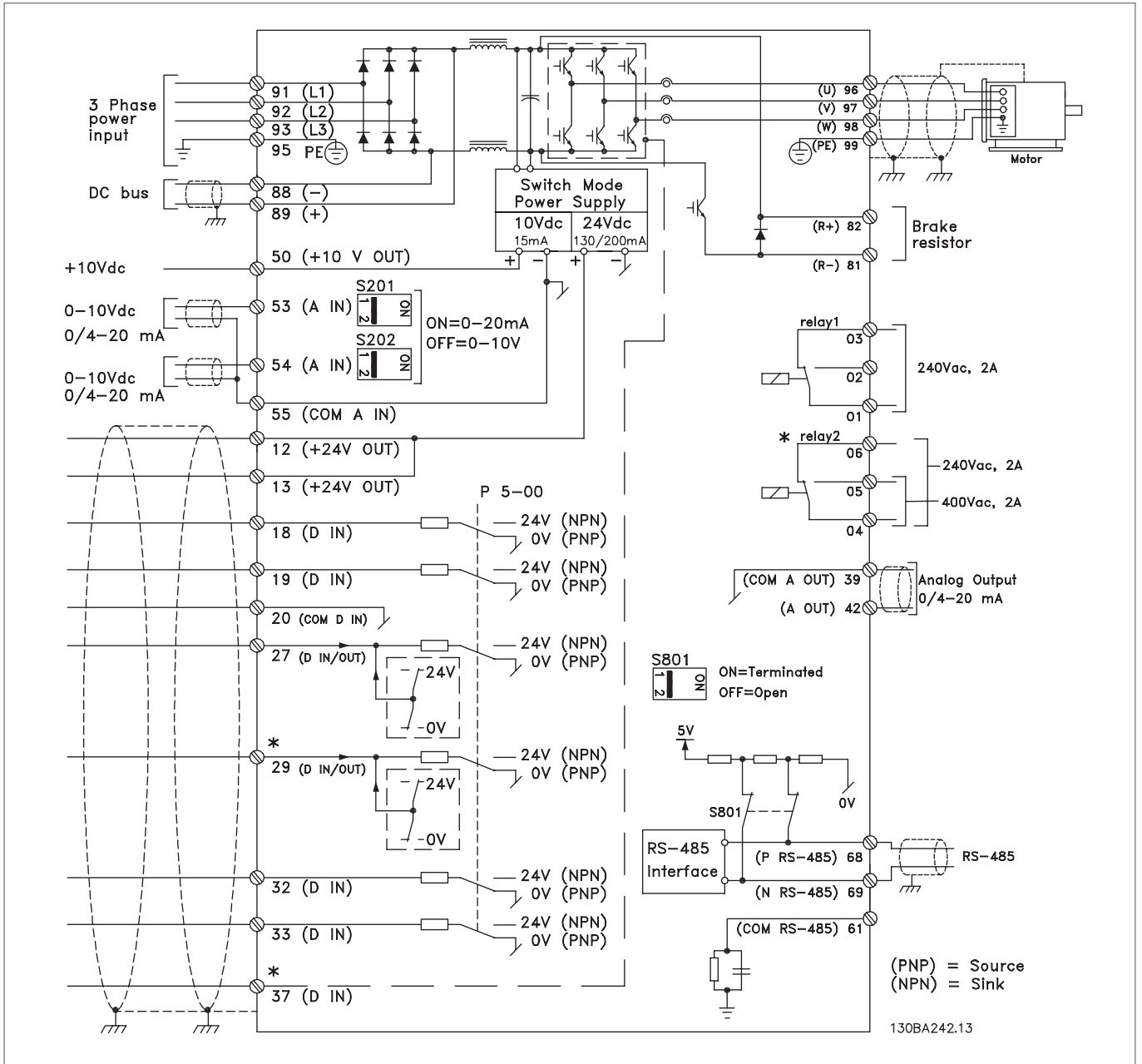

*FC 302 only. Additional safe stop input on FC 302 and FC 301 A1 (Terminal 37)

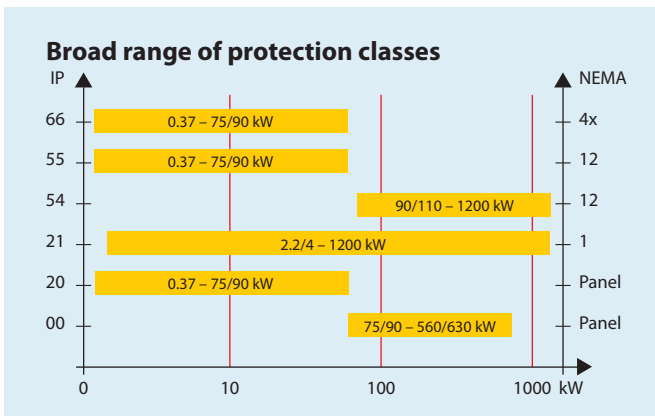

An external watertight USB plug connected to the control card inside IP 55/66 enclosures makes USB access easy.



Typical current and power ratings

FC 300	200 – 240 V				380 – 480 V (FC 302 up to 500V)						525 – 600 V Not FC 301				525 – 690 V Not FC 301													
	kW NO	kW HO	Amp. NO HO		IP 20	IP 21	IP 55	IP 66	NO	HO	IP 00	IP 20	IP 21	IP 54	IP 55	IP 66	Amp. NO	HO	IP 20	IP 21	IP 55	IP 66	Amp. NO	HO	IP 00	IP 21	IP 54	
PK25		0.25	1.8																									
PK37		0.37	2.4						1.3																			
PK55		0.55	3.5		A1*	A1*			1.8																			
PK75		0.75	4.6		A2	A2			2.4		A1*	A2					1.8											
P1K1		1.1	6.6				A5	A5	3					A5	A5		2.6											
P1K5		1.5	7.5						4.1		A2						2.9		A2	A2	A5	A5						
P2K2		2.2	10.6		A2	A2			5.6		A2	A2					4.1											
P3K0		3	12.5		A2	A2			7.2		A2	A2					5.2											
P3K7		3.7	16.7		A3	A3																						
P4K0	5.5	4	24.2						10		A2	A2					6.4		A2	A2								
P5K5	7.5	5.5	30.8	24.2					13		A3	A3			A5	A5	9.5		A3	A2		A5	A5					
P7K5	11	7.5	46.2	30.8	B3	B1	B1	B1	16								11.5		A3	A2								
P11K	15	11	59.4	46.2	B4	B2	B2	B2	32	24	B3	B1		B1	B1	18	13	B3	B1	B1	B1							
P15K	18.5	15	74.8	59.4					37.5	32						22	18											
P18K	22	18	88	74.8	C3	C1	C1	C1	44	37.5		B2		B2	B2	27	22		B2	B2	B2							
P22K	30	22	115	88					61	44	B4					34	27											
P30K	37	30	143	115					73	61						41	34											
P37K	45	37	170	143	C4	C2	C2	C2	90	73	C3	C1		C1	C1	52	41	C3	C1	C1	C1	54	46		D3	D1	D1	
P45K	55	45							106	90						62	52					73	54					
P55K	75	55							147	106	C4	C2		C2	C2	83	62	C4	C2	C2	C2	86	73					
P75K	90	75							177	147						100	83					108	86		D3	D1	D1	
P90K	110	90							212	177												131	108					
P110	132	110							260	212	D3		D1	D1								155	131					
P132	160	132							315	260												192	155					
P160	200	160							395	315	D4		D2	D2								242	192		D4	D2	D2	
P200	250	200							480	395												290	242					
P250	315	250							600	480												344	290					
P315	355	315							658	600												400	344					
P355	400	355							745	658	E2		E1	E1								450	380					
P400	450	400							800	695												450	380					
P450	500	450							880	800												500	410		E2	E1	E1	
P500	560	500							990	880												570	500					
P560	630	560							1120	990		F1/F3	F1/F3									630	570					
P670	710	630							1260	1120												730	630					
P710	800	710							1460	1260		F2/F4	F2/F4									850	730		F1/F3	F1/F3		
P800	900	800							1700	1460												945	850					
P900	1000	900																				1060	945			F2/F4	F2/F4	
P1M0	1200	1000																				1260	1060			F2/F4	F2/F4	

*VLT® AutomationDrive FC 301 – HO: 110% for 60 sec. – NO: 160/150% for 60 sec.

IP 00/Chassis	IP 20/Chassis	IP 21/NEMA Type 1	IP 54/NEMA Type 12	IP 55/NEMA Type 12	IP 66/NEMA Type 4X
---------------	---------------	-------------------	--------------------	--------------------	--------------------

Dimensions [mm]

	A1	A2	A3	A5	B1	B2	B3	B4	C1	C2	C3	C4	D1	D2	D3	D4	E1	E2	F1	F2	F3	F4
H	200	268		420	481	651	350	460	681	770	490	600	1209	1589	1046	1327	2000	1547	2204		2282	
W	75	90	130		242		165	230	308	370	306	370		420		408	600	585	1400	1800	2000	2400
D		205		200	261		248	242	310		335		380		375		494	498	606		607	
H+		308	372				490	675			760	955										
W+		94	134				170	255			330	395										

H+ and W+ is the height and width with IP upgrade kit

Configure freely

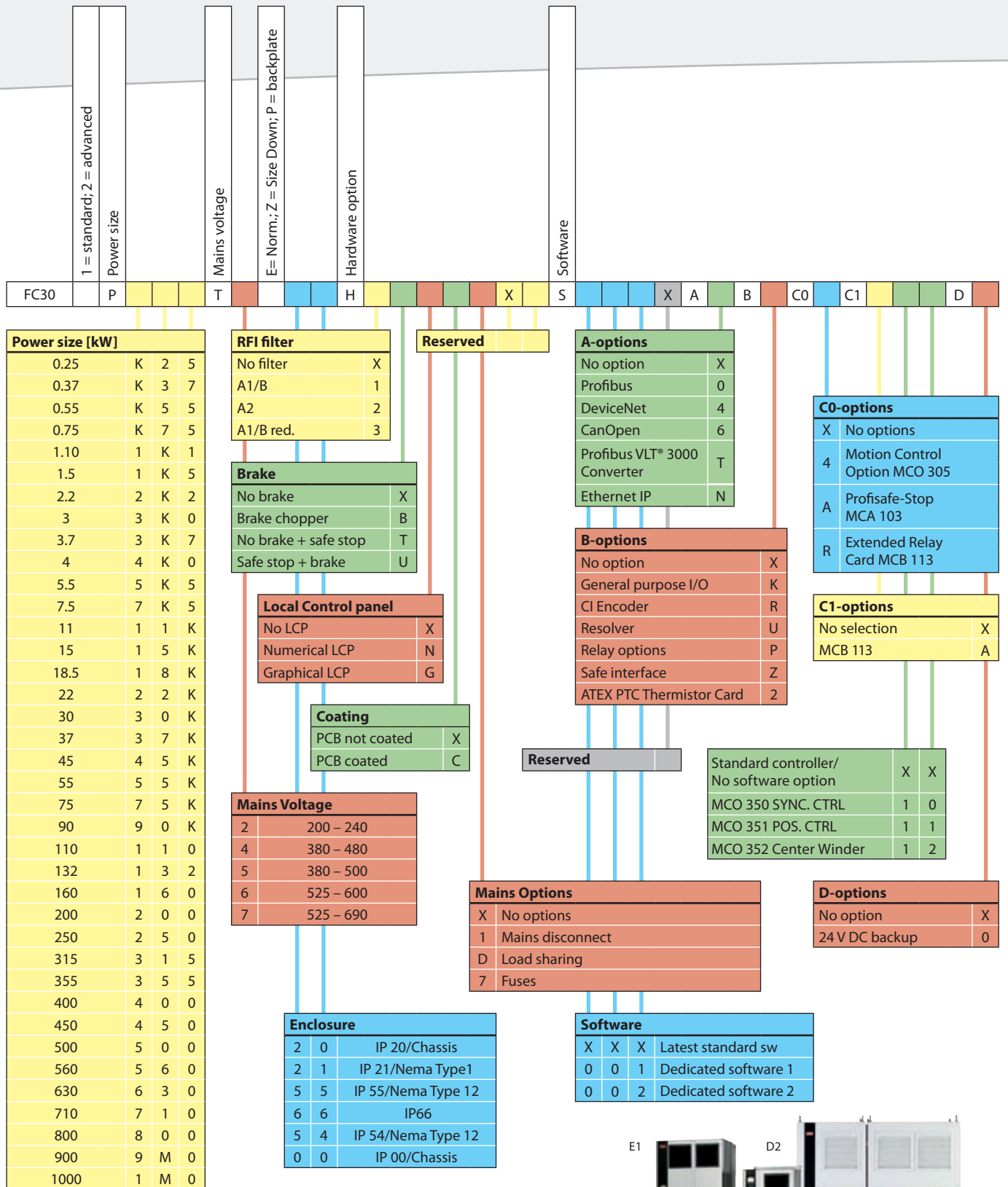

These are the thousands of ways to configure a VLT® AutomationDrive. By choosing between options, you define your unique drive number.

Your drive is factory built from this number. You can configure online at www.danfoss.com/drives – choose "Online Configurator".

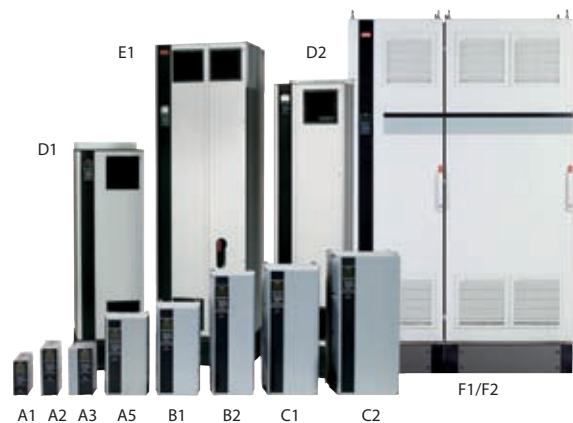



Environmentally responsible

VLT® products are manufactured with respect for environment, safety and well-being.

All activities are planned and performed taking into account the individual employee, the work environment and the external environment. Production takes place with a minimum of noise, smoke or other pollution and environmentally safe disposal of the products is assured.

UN Global Compact

Danfoss has signed the UN Global Compact on social and environmental responsibility and our companies act responsibly towards local societies.

EU Directives

All factories are certified according to ISO 14001 standard. All products fulfil the EU Directives for General Product Safety and the Machinery directive. Danfoss Drives is, in all product series, implementing the EU Directive concerning Hazardous Substances in Electrical and Electrical Equipment (RoHS) and is designing all new product series according to the EU Directive on Waste Electrical and Electronic Equipment (WEEE).

Impact on energy savings

One year's energy savings from VLT® drives will save the energy equivalent to the energy production from a power plant. Better process control at the same time improves product quality and reduces waste and wear on equipment.

What VLT® is all about

Danfoss Drives is the world leader among dedicated drives providers – and still gaining market share.

Dedicated to drives

Dedication has been a key word since 1968, when Danfoss introduced the world's first mass produced variable speed drive for AC motors – and named it VLT®.

Two thousand employees develop, manufacture, sell and service drives and softstarters in more than one hundred countries, focused only on drives and softstarters.

Intelligent and innovative

Developers at Danfoss Drives have fully adopted modular principles in development as well as design, production and configuration.

Tomorrow's features are developed in parallel using dedicated technology platforms. This allows the development of all elements to take place in parallel, at the same time reducing time to market and ensuring that customers always enjoy the benefits of the latest features.

Rely on the experts

We take responsibility for every element in our products. The fact that we develop and produce our own features, hardware, software, power modules, printed circuit boards, and accessories is your guarantee for reliable products.

Local backup – globally

VLT® motor controllers are operating in applications all over the world and Danfoss Drives' experts located in more than 100 countries are ready to support our customers with application advice and service wherever they may be.

Danfoss Drives experts don't stop until the customer's drive challenges are solved.

