

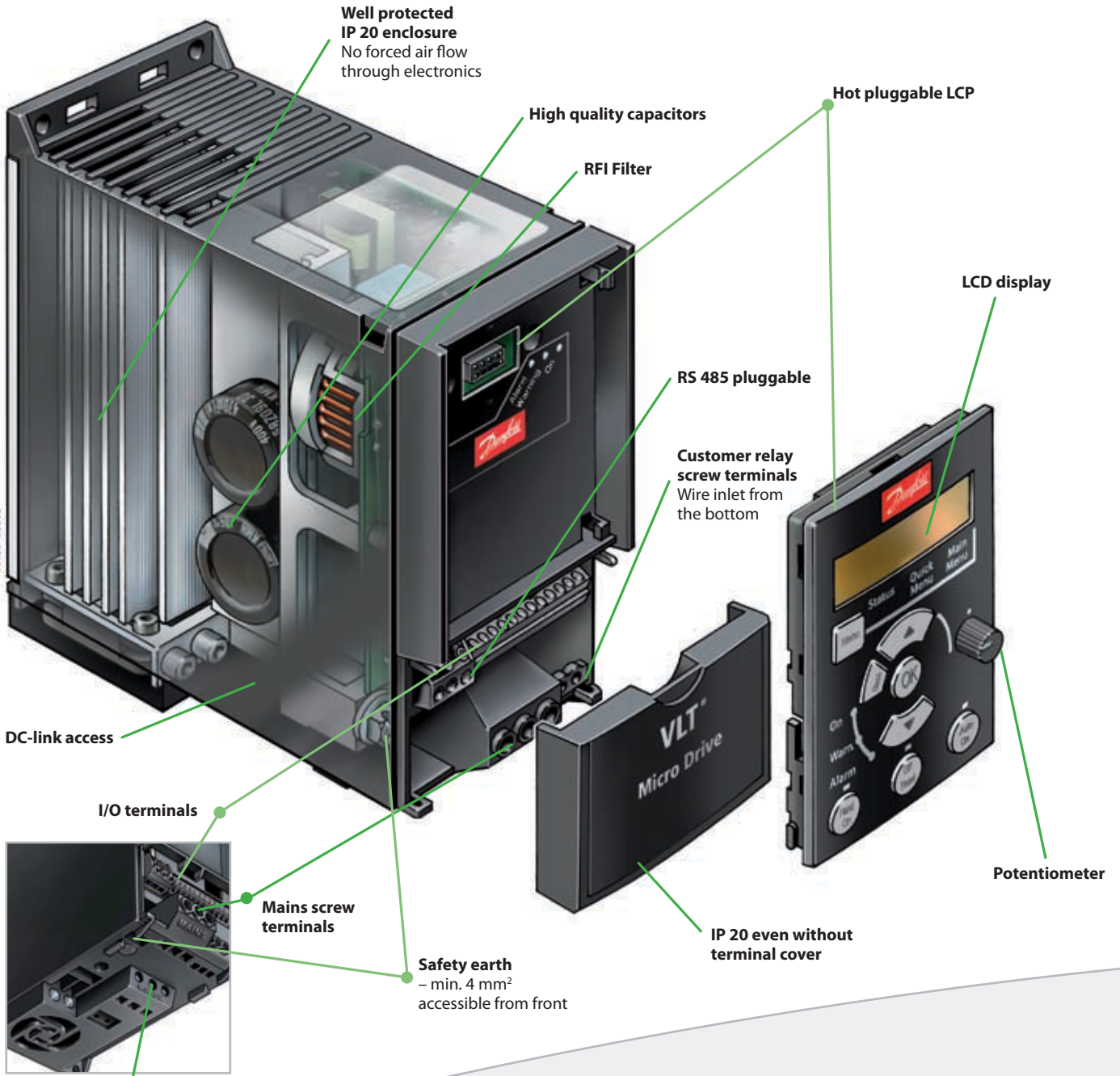

VLT® Micro Drive

Small drive – maximum strength and reliability



Ready – Steady – Go!

Connect motor and power cables, turn the control knob, and watch the motor speed change.

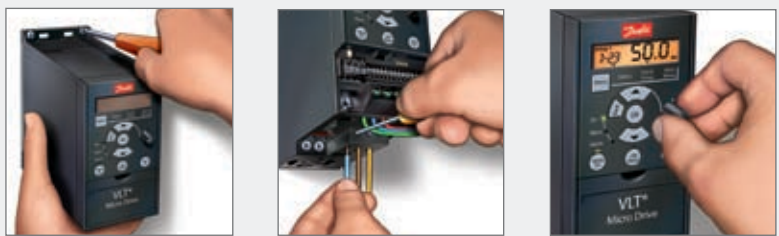

RoHS compliant
The VLT® Micro Drive does not contain lead, cadmium, hexavalent chrome, mercury, or flame retardant PBB and PBDE.



Compact VLT® quality

VLT® Micro Drive is a genuine VLT® frequency converter with unsurpassed reliability, user-friendliness, condensed functionality, and extremely easy to commission. Terminal numbers are named in the same manner as in the rest of the VLT® family. It's developed and manufactured by Danfoss Drives, the leading drives experts since 1968 and creators of VLT® – The Real Drive.

User friendly

VLT® Micro Drive shares the user-friendliness of the VLT® family.

- Plug-and-play – Minimum effort – minimum time
- Minimum commissioning – Save time
- Copy settings via local control panel – Easy set up of multiple drives
- Intuitive parameter structure – Minimal manual reading
- Complies with VLT® software – Save commissioning time

Reliable

VLT® Micro Drive is a full member of the VLT® family sharing the overall quality of design, reliability and user-friendliness. High quality components and genuine VLT® solutions makes VLT® Micro Drive extremely reliable.

- Optimum heat dissipation – Longer lifetime
- High quality electronics/capacitors – Low lifetime cost
- All drives full load tested from factory – High reliability
- Earth fault, temperature and short circuit protection – Lean operation
- Circuit boards well protected and coated – Increased robustness

Small drive – high performance

Despite the compact size and the easy commissioning, VLT® Micro Drive can be set up to perform perfectly even in complex application set-ups. Approximately 100 parameters can be set to optimize energy efficiency and operation.

- Process PI-controller – No need for external controller
- Automatic Energy Optimizer (AEO) – Less energy consumption
- Automatic Motor Tuning (AMT) – Exploit motor's full potential
- 150% motor torque up to 1 minute – Replace need for bigger drive
- Flying start (catch a spinning motor) – Lean operation – more up-time
- Electronic Thermal relay (ETR) – Replace external motor protection
- Smart Logic Controller – Often makes PLC ommissible
- Built-in RFI filter – Save cost and space

In- and outputs

- 5 programmable Digital inputs
- PNP/NPN selection
- Pulse input 20 – 5000 Hz
- 1 Analogue input 0 – 10 V or 0 – 20 mA
- 1 analogue input 0 – 20 mA
- Thermistor input (analogue/digital)
- 1 Analogue output 0 – 20 mA
- 1 Relay 240 V AC, 2 A
- RS485 FC-bus
- Modbus RTU

Compact general purpose drive

The VLT® Micro Drive is a general purpose drive that can control AC motors up to 7.5 kW.



Compact design Uncompromised quality

Ensured reliability and maximum up/time



Real space saving side-by-side

A compact book style design allows real side by side mounting without derating.

Minimum penetration of dust

VLT® Micro Drive is designed to keep the forced ventilation away from the electronics. Printed circuit boards are well protected inside the drive.

Built-in RFI

Radio disturbance from motor cables is limited with the built-in RFI filter

allowing for 15 m motor cables (screened). Meets EU norms.

Built-in brake functions

With built in DC and AC brake functions, VLT® Micro Drive can transform kinetic energy in the application into braking power to slow down the motor. A brake chopper is built-in the drives from 1.5 kW upwards.

Designed for reliability in industrial applications



Intelligent heat management

Process heat is removed through the heat sink, leaving electronics protected from dust and dirt from production.

Effective heat sink

An effective heat sink easily removes heat from the electronics, extending lifetime and reliability of the drive.

Coated electronics are standard

All VLT® Micro Drive comes with coated electronics for longer lifetime and reliability.

50° ambient temperature

Highly efficient cooling allows up to 50° ambient temperature.

Energy efficiency 98%

High quality VLT® power modules ensure cool running of the drive due to low losses.

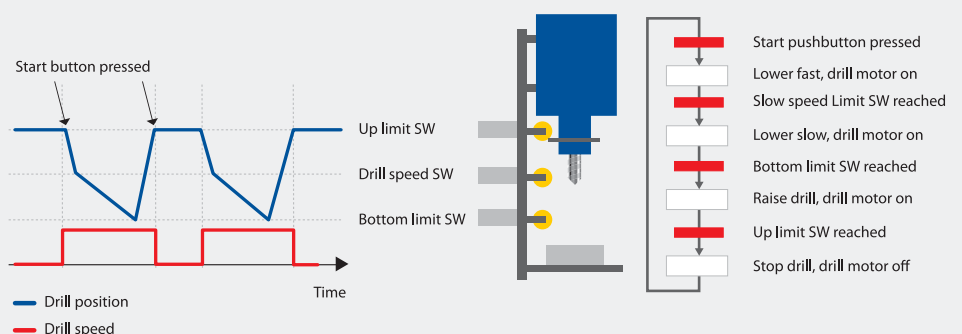

Hot pluggable display – with or without potentiometer

- LCP without potentiometer IP 54
- LCP with potentiometer IP 21
- Remote mounting kit
- LCP copy function
- Parameter numbers and values visible simultaneously
- Unit indications (A., V, Hz, RPM, %, s, HP and kW)
- Rotation direction indication
- Setup indication – 2 setup
- Removable during operation
- Up- and download functionality

Large figures, easy to read

- Display readable from distance
- Operation buttons are illuminated when active

Quick Menus

- A Danfoss defined Quick Menu
- Basic settings
- PI controller

Menu structure

- Based on the well-known matrix from the VLT® family
- Easy shortcut for the experienced user
- Edit and operate in different set-ups simultaneously

Remote mountable

Illuminated LCD display

Navigation buttons

Indicators
Operation buttons



Two control panel versions.
Potentiometer is optional.

The control panels are shown in actual size.
H x W x D = 85 x 65 x 20 mm
(D = 28 mm w. potmeter)

Built-in Smart Logic Controller

The smart logic controller is a simple, and yet very clever way to have your drive, motor and application working together.

The smart logic controller is able to monitor any parameter that can be characterized as "true" or "false".

This includes digital commands and also logic expressions, which allows even sensor outputs to influence the

operation. Temperature, pressure, flow, time, load, frequency, voltage and other parameters combined with the operators ">", "<", "=", "and" and "or" forms logic expressions that are false or true.

That is why Danfoss calls it a "logic" controller. As a result of this, you can program the controller to react on literally any event.

Connections

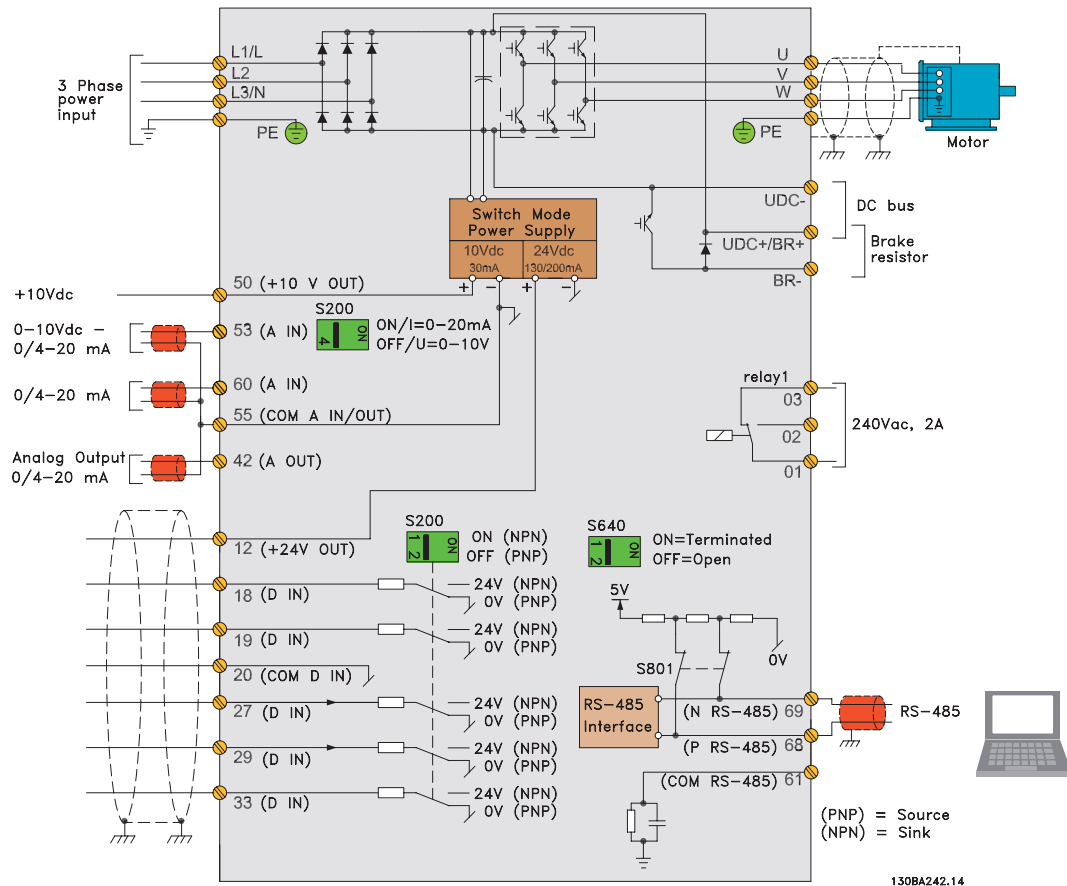

Factory settings

Accessories



Set-up software

The VLT® Motion Control Tool MCT 10 Setup Software exploits the full functionality of your PC, providing a general overview and control of even large systems.



Remote mounting kit

A dedicated mounting kit is available for mounting the local control panel (LCP) in the cabinet door.

Code numbers

VLT® Control panel LCP 11
W/o potentiometer..... 132B0100

VLT® Control panel LCP 12
With potentiometer..... 132B0101

Remote mounting kit
incl. 3 m cable..... 132B0102

Decoupling plate

For EMC optimized installation.

Dedicated external filters are available on request.

Specifications

Mains supply (L1, L2, L3)

Supply voltage	1 x 200–240 V ± 10%
Supply voltage	3 x 200–240 V ± 10%
Supply voltage	3 x 380–480 V ± 10%

Output data (U, V, W)

Output voltage	0–100% of supply voltage
Output frequency	0–200 Hz (VVC+ mode)
Output frequency	0–400 Hz (U/f mode)
Switching on output	Unlimited
Ramp times	0.05–3600 sec

Digital inputs

Programmable inputs	5
Logic	PNP or NPN
Voltage level	0–24 V
Maximum voltage on input	28 V DC
Input Resistance, Ri	Approx. 4 kΩ

Pulse inputs

Programmable pulse inputs	1
Voltage level	0–24 V DC (PNP positive logic)
Pulse input accuracy (0,1–110 kHz)	Max. error: 0.1% of full scale
Pulse input frequency	20–5000 Hz

Analog input

Analog inputs	2
Modes	1 current/1 voltage or current
Voltage level	0–10 V (scaleable)
Current level	0/4– (scaleable)

Analog output

Programmable analog outputs	1
Current range at analog output	0/4–20 mA
Max. load to common at analog output	500 Ω
Accuracy on analog output	Max. error: 1% of full scale

Ordering numbers

Power [kW]	200 V		400 V		
	Current [I-nom.]	1 ph.	3 ph.	Current [I-nom.]	3 ph.
0.18	1.2	132F 0001			
0.25	1.5		132F 0008		
0.37	2.2	132F 0002	132F 0009	1.2	132F 0017
0.75	4.2	132F 0003	132F 0010	2.2	132F 0018
1.5	6.8	132F 0005	132F 0012	3.7	132F 0020
2.2	9.6	132F 0007	132F 0014	5.3	132F 0022
3.0				7.2	132F 0024
3.7	15.2		132F 0016		
4.0	Micro drives from 1.5 kW and up have built in brake chopper			9	132F 0026
5.5				12	132F 0028
7.5				15.5	132F 0030

On-board power supply

Output voltage	10.5 ± 0.5 V
Max. load (10 V)	15 mA
Max. load (24 V)	130 mA

Relay outputs

Programmable relay outputs	1
Max. terminal load	240 V AC, 2 A

Cable lengths

Max. motor cable length, screened (shielded)	15 m
Max. motor cable length, unscreened (unshielded)	50 m

Surroundings/ External

Enclosure	IP 20
Vibration test	0.7 g
Max. relative humidity	5%–95% (IEC 721-3-3; Class 3K3 (non-condensing) during operation)
Aggressive environment	(IEC 721-3-3), coated class 3C3
Ambient temperature	Max. 50° C
24-hour average	Max. 40° C

Protection and features

- Electronic thermal motor protection against overload
- Temperature monitoring of the heat sink protects the drive from overheating
- The drive is protected against short-circuits on motor terminals U, V, W
- The drive is protected against earth fault on motor terminals U, V, W



Cabinet sizes

(mounting brackets incl.)

[mm]	M1	M2	M3
Height	150	180	239
Width	70	75	90
Depth	148	168	194

+ 6 mm with potentiometer



Environmentally responsible

VLT® products are manufactured with respect for the safety and well-being of people and the environment.

All activities are planned and performed taking into account the individual employee, the work environment and the external environment. Production takes place with a minimum of noise, smoke or other pollution and environmentally safe disposal of the products is prepared.

UN Global Compact

Danfoss has signed the UN Global Compact on social and environmental responsibility and our companies act responsibly towards local societies.

EU Directives

All factories are certified according to ISO 14001 standard. All products fulfil the EU Directives for General Product Safety and the Machinery directive. Danfoss Drives is, in all product series, implementing the EU Directive concerning Hazardous Substances in Electrical and Electrical Equipment (RoHS) and is designing all new product series according to the EU Directive on Waste Electrical and Electronic Equipment (WEEE).

Impact on energy savings

One year's energy savings from the annual production of VLT® drives will save the energy equivalent to the energy production from a power plant. Better process control at the same time improves product quality and reduces waste and wear on equipment.

What VLT® is all about

Danfoss Drives is the world leader among dedicated drives providers – and still gaining market share.

Dedicated to drives

Dedication has been a key word since 1968, when Danfoss introduced the world's first mass produced variable speed drive for AC motors – and named it VLT®.

Two thousand employees develop, manufacture, sell and service drives and softstarters in more than one hundred countries, focused only on drives and soft starters.

Intelligent and innovative

Developers at Danfoss Drives have fully adopted modular principles in development as well as design, production and configuration.

Tomorrow's features are developed in parallel using dedicated technology platforms. This allows the development of all elements to take place in parallel, at the same time reducing time to market and ensuring that customers always enjoy the benefits of the latest features.

Rely on the experts

We take responsibility for every element of our products. The fact that we develop and produce our own features, hardware, software, power modules, printed circuit boards, and accessories is your guarantee of reliable products.

Local backup – globally

VLT® motor controllers are operating in applications all over the world and Danfoss Drives' experts located in more than 100 countries are ready to support our customers with application advice and service wherever they may be.

Danfoss Drives experts don't stop until the customer's drive challenges are solved.

