

Multiturn Type 9080 CANopen/DeviceNet™



Your benefit

- Only 60 mm clearance needed
- Patented integrative technology
- Very easy mounting of the hollow shaft version. The encoder is mounted directly on the drive shaft without coupling. This saves up to 30 % cost and 50 % clearance compared to shaft versions.
- Divisions: up to 8192 (13 bits) per revolution, 4096 (12 bits) revolutions
- Non-contact multiturn gear with new Intelligent-Sensing-Technology (IST)

- Simply connection patent pending connecting system with removable socket box
 - Protection: IP65
- Product features
- CANopen according to profile DSP 406 with additional features
 - DeviceNet™ 2.0 protocol
 - Divisions: up to 8192 bits per revolution, up to 4096 revolutions (13 x 12 bit)
 - IP65
 - Extensive M12 accessories program

Mechanical characteristics:

Speed: ¹⁾	max. 6000 min ⁻¹
Rotor moment of inertia:	approx. 72 x 10 ⁻⁶ kgm ²
Starting torque shaft hollow shaft version :	< 0.2 Nm
Starting torque shaft shaft version :	< 0.05 Nm
Load capacity of shaft (using solid shaft) ²⁾	radial: 80 N, axial 40 N
Weight:	approx. 0.9 kg
Protection acc. to EN 60529:	IP65
EX approval for hazardous areas:	optional zone 2 and 22
Working temperature:	-10° C ... +70 °C ³⁾
Shaft:	stainless steel, hollow shaft H7
Shock resistance acc. to DIN-IEC 68-2-27:	2500 m/s ² , 6 ms
Vibration resistance acc. to DIN-IEC 68-2-6:	100 m/s ² , 10 ... 2000 Hz

¹⁾ For continuous operation 3000 min⁻¹

²⁾ Shaft version only (at shaft end)

³⁾ Non-condensing

CANopen
DeviceNet.

Electrical characteristics:

Supply voltage (U _B):	10 ... 30 V DC
Current consumption:	max. 0.29 A
recommended fuse:	T 0,315 A
Linearity:	± 1/2 LSB (±1 LSB with resolution 13, 14, 25 Bit)
Code:	Binary
Interface:	CAN HIGH-Speed to ISO/DIS 11898, Basic and Full-CAN; CAN-specification 2.0 B (11 and 29 Bit Identifier)
Protocol:	CANopen to Profile DSP 406 DeviceNet™ Profile for Encoder Release V 2.0
Baud rate:	programmable via DIP switches 10 ... 1000 Kbits/s
Basic identifier/node:	programmable via DIP switches
Conforms to CE requirements acc. to EN 61000-6-1, EN 61000-6-4 and EN 61000-6-3	
Performance against magnetic influence acc. to EN61000-4, 5	
UL certified	File 224618 (version with terminal box)
RoHS compliant acc. to EU guideline 2002/95/EG	

Multiturn Type 9080 CANopen/DeviceNet™

CANopen - Device Profile:

General description

The CANopen Device Profiles describe the functionality of the communication and of that part of the CANopen fieldbus system specific to the manufacturer. Device Profile 406 applies to encoders and defines the individual objects independently of the manufacturer. In addition the profile makes provision for additional extended functions specific to the manufacturer; using devices that interface with CANopen offers the advantage of acquiring systems today that are prepared for the needs of the future.

The following functionality is integrated:

- Class C2 functionality
- NMT Slave
- Diagnostics (internal) 2 Bit
- CAN-LED for Bus status
- CAN-LED for operating mode

The following parameters can be programmed:

- Polling mode or auto mode with adjustable time
- Direction
- Number of pulses/rotation 1 ... 8192
- Number of revolutions 1 ... 4096
- Total resolution
- Preset
- Offset

DeviceNet™ Encoder Profile:

General description:

The DeviceNet™ Device Profile describes the functionality of the communication and of that part of the DeviceNet™ fieldbus system specific to the manufacturer. The Encoder Profile applies to encoders and defines the individual objects independently of the manufacturer. In addition the profile makes provision for additional extended functions specific to the manufacturer.

The following functionality is integrated:

- Galvanic isolation of the Fieldbus-stage with DC/DC converter
- Addressing via DIP switches or software
- Diagnostic LED for network and mode
- Baud rate 125, 250 and 500 kbit/s programmable via DIP switches
- Node address 0 ... 63 and baud rate programmable via DIP switches
- Polled mode
- Cyclic mode
- Change of state mode (COS)
- Combination of Polled mode and Cyclic mode
- Combination of Polled mode and COS mode
- Offline connection set
- Device heartbeat
- "Out of box" Configuration
- MAC-ID and Baud rate preset value
MAC-ID = 63

- Baud rate = 125 kBits/s
- 2 I/O Assembly
Position value
Position value and status

The following parameters can be programmed:

- Direction of rotation
- Scaling factor
 - Number of pulses/rotation
 - Total resolution
- Number of revolutions
- Preset value
- Diagnostics mode
- Resolution

Fieldbus encoders can be used in following applications:

CANopen:

Elevators, construction and mobile plant, cranes, agricultural vehicles, special-purposes vehicles.

DeviceNet™:

especially suitable for applications in the USA.

Rotary Measuring Technology

Absolute encoders, Multiturn, with CANopen/DeviceNet™ interface

TURCK

Industrial
Automation

Multiturn Type 9080 CANopen/DeviceNet™

Bus in:

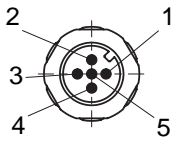

Signal :	DRAIN	+ V DC	- V DC	CAN_H	CAN_L
Pin:	1	2	3	4	5
	GY	RD	BK	WH	BU

Bus out:

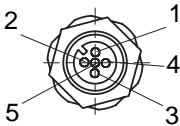

Signal :	DRAIN	+ V DC	- V DC	CAN_H	CAN_L
Pin:	1	2	3	4	5
	GY	RD	BK	WH	BU

Use Couplings for the connection BUS-IN and Connectors for the connection BUS-OUT.
Compatible self-assembly connectors:

Connector (BUS-OUT): 05.B8251-0/9
Coupling (BUS-IN): 05.B8151-0/9
See also Connection Technology section for cable assemblies.

Dimensions:

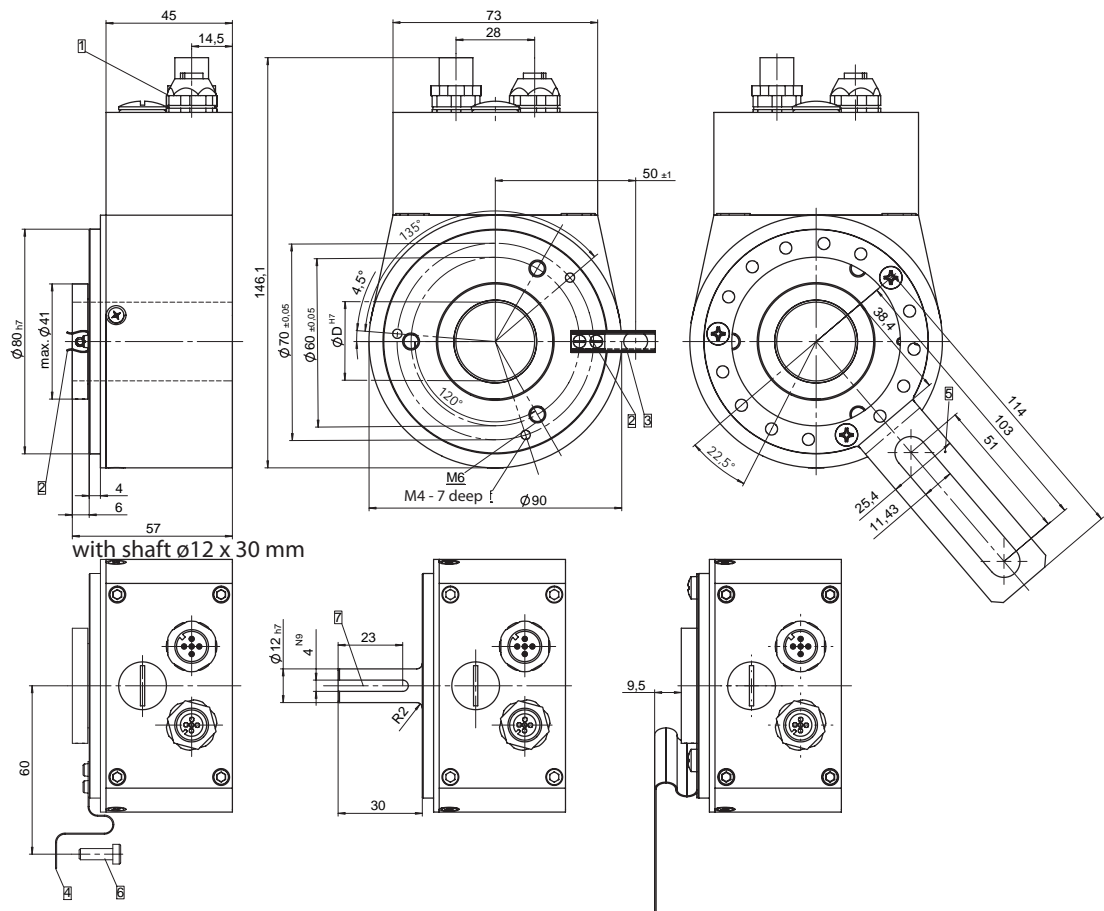

- | | |
|---|----------------------------------|
| 1 M12 Connectors/Coupling | 5 Mounting Flange (Flange No. 5) |
| 2 Spring device short (FlangeNo. 2) for pin acc. to DIN 6325 ϕ 6 | 6 Slotted hole for screw M4 |
| 3 Spring device long (Flange No. 3) for pin acc. to DIN 6325 ϕ 6 | 7 2,5 mm deep |
| 4 Mounting Flange (Flange No. 4) | |

Multiturn Type 9080 CANopen/DeviceNet™

Terminal assignment with terminal box:

Signal :	ENC.		BUS IN			BUS OUT			ENC.		Shield ¹⁾	
	+V DC	GND	GND	CAN_H	CAN_L	CAN_L	CAN_H	GND	GND	+V DC		
Pin:	1	2	3	4	5	6	7	8	9	10	11	12

¹⁾ only DeviceNet™ version

Dimensions (terminal box version):

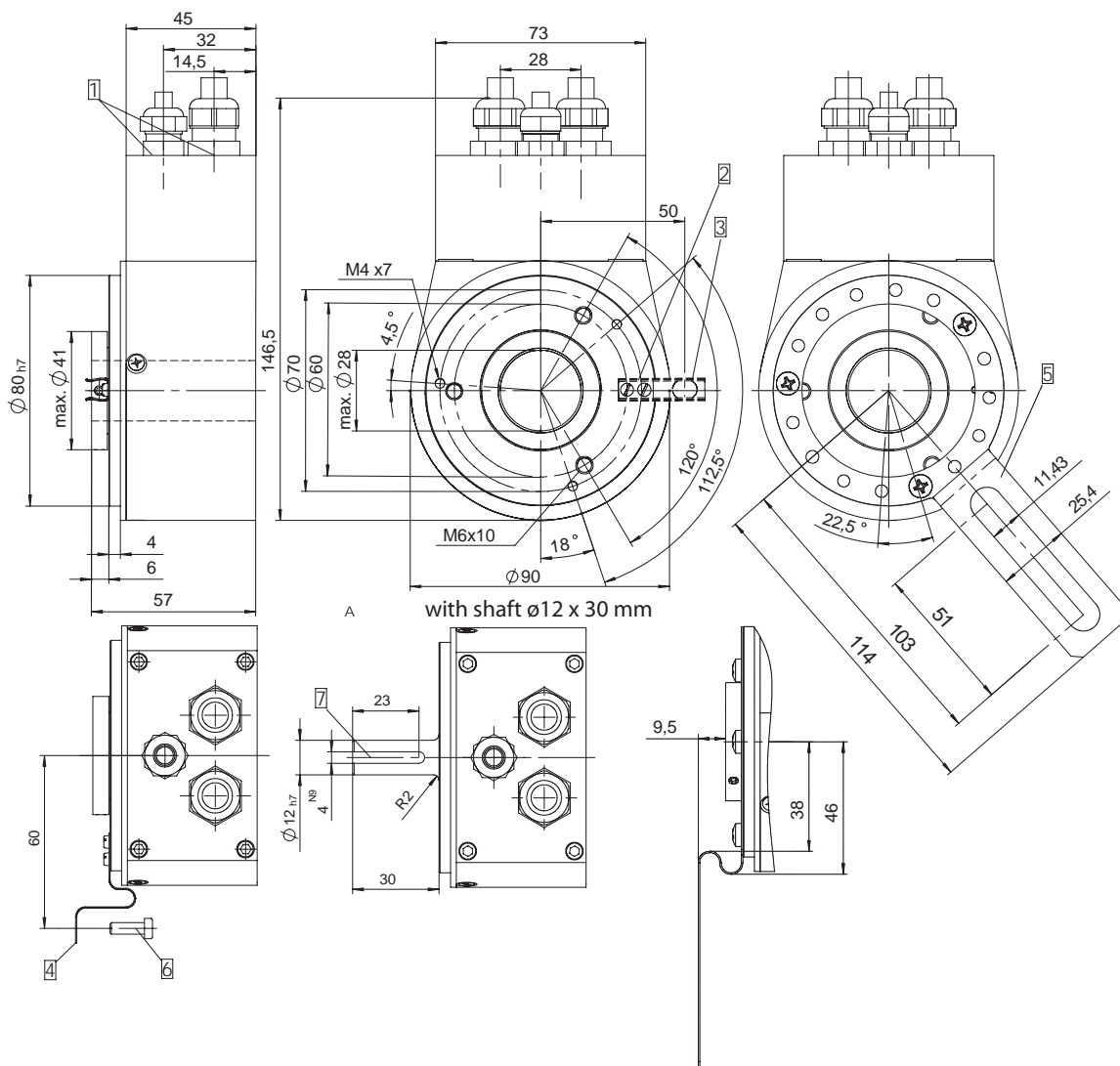

- 1 Socket box
- 2 Spring device short (Flange No. 2) for pin acc. to DIN 6325 \varnothing 6
- 3 Spring device long (Flange No. 3) for pin acc. to DIN 6325 \varnothing 6
- 4 Mounting flange (Flange No. 4)
- 5 Mounting flange (Flange No. 5)
- 6 Slotted hole for screw M4
- 7 2,5 mm deep

Mounting advice:

The flanges and shafts of the encoder and drive should not both be rigidly coupled together at the same time!

Multiturn Type 9080 CANopen/DeviceNet™

Bus in:

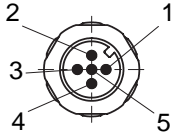

Signal :	DRAIN	+ V DC	- V DC	CAN_H	CAN_L
Pin:	1	2	3	4	5
	GY	RD	BK	WH	BU

Bus out:

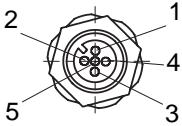

Signal :	DRAIN	+ V DC	- V DC	CAN_H	CAN_L
Pin:	1	2	3	4	5
	GY	RD	BK	WH	BU

Use Couplings for the connection BUS-IN and Connectors for the connection BUS-OUT.

Dimensions (M12 connector version):

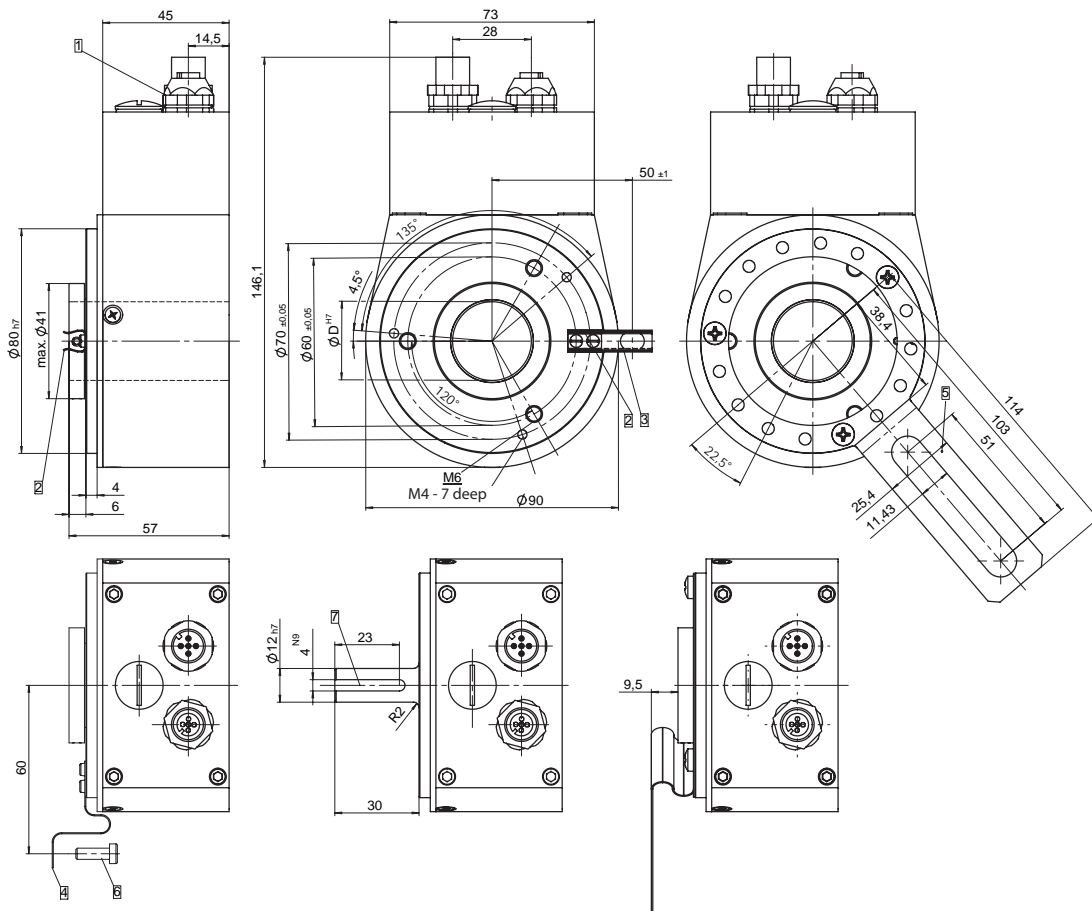

- 1 M12 Connectors/Coupling
- 2 Spring device short (Flange No. 2)
- 3 Spring device long (Flange No. 3)
- 4 Flange (Flange No. 4)
- 5 Tether arm (Flange No. 5)
- 6 Slotted hole for screw M4
- 7 2,5 mm deep

Rotary Measuring Technology

Absolute encoders, Multiturn, with CANopen/DeviceNet™ interface



Multiturn Type 9080 CANopen/DeviceNet™

Patented "Integrated Technology®" uses single board construction, deliberate assembly techniques, and two ASIC design:

- Shock up to 250gs
- Higher vibration specs and thermal shock performance
- Lower parts count, elimination of potentiometers
- Higher resistance to EMI

Electronic multiturn increases performance, eliminates gears

- Reliability - No backlash errors, resistant to EMI, lower parts count
- Higher life - No mechanical wear, lower internal temperature
- Higher performance - Higher operating speeds
- Lower profile - compact size, hollow shaft
- Economical - Lower cost

Patented "Intelligent Sensing Technology®"

- The battery outlasts both application requirements and system components (LEDs & bearings)
- Redundant multiturn sensors and counters increase reliability & life
- Active system output monitoring using digital filters to compare data to logical & target bits.

Order code:

T8.9080.XX XX.X001

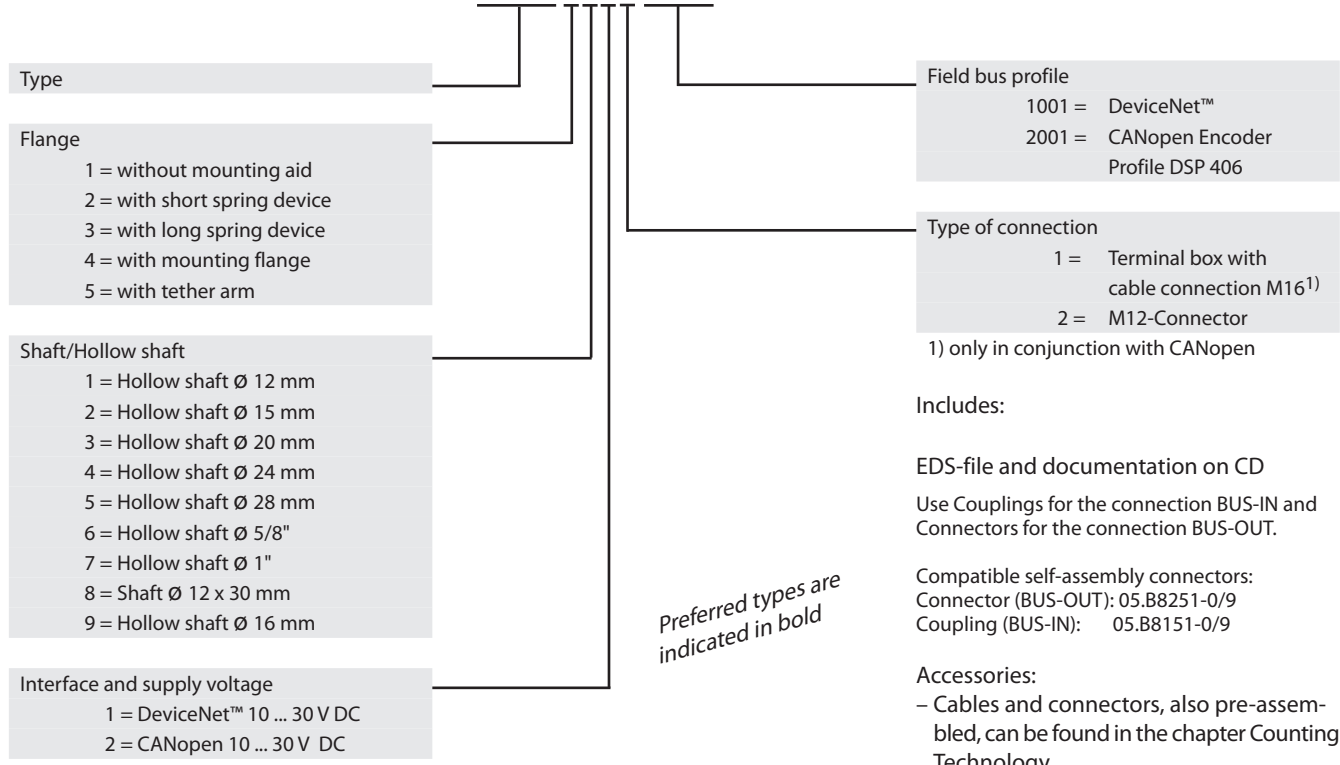

Includes:

EDS-file and documentation on CD

Use Couplings for the connection BUS-IN and Connectors for the connection BUS-OUT.

Compatible self-assembly connectors:
Connector (BUS-OUT): 05.B8251-0/9
Coupling (BUS-IN): 05.B8151-0/9

Accessories:

- Cables and connectors, also pre-assembled, can be found in the chapter Counting Technology
- Mounting attachments and couplings can be found in the Chapter Accessories