



## The E-connect system

Safely stopping motion is becoming more critical as machinery and systems become more automated. Where once a machine was controlled by one person, today we have many interconnect machines that are controlled by Industrial PCs and PLCs. Motion may start automatically without warning, and some of today's equipment is almost silent in comparison to the background noise of the factory.

**TURCK has developed three systems to quickly connectorize standard e-stop devices.**

- 1) Series E-connect
- 2) Series E-connect with bus monitoring and annunciation
- 3) Dedicated E-connect

### Series E-connect

Series connection of redundant e-stop device contacts is one of the most common ways in North America to provide machine safety for personnel. Two isolated circuits go from the safety relay module to the redundant contacts of each emergency stop devices.

### Dedicated E-connect

Two dedicated circuits go from the safety relay module to redundant contacts of a single emergency stop, or safeguarding device.

## E-connect Station

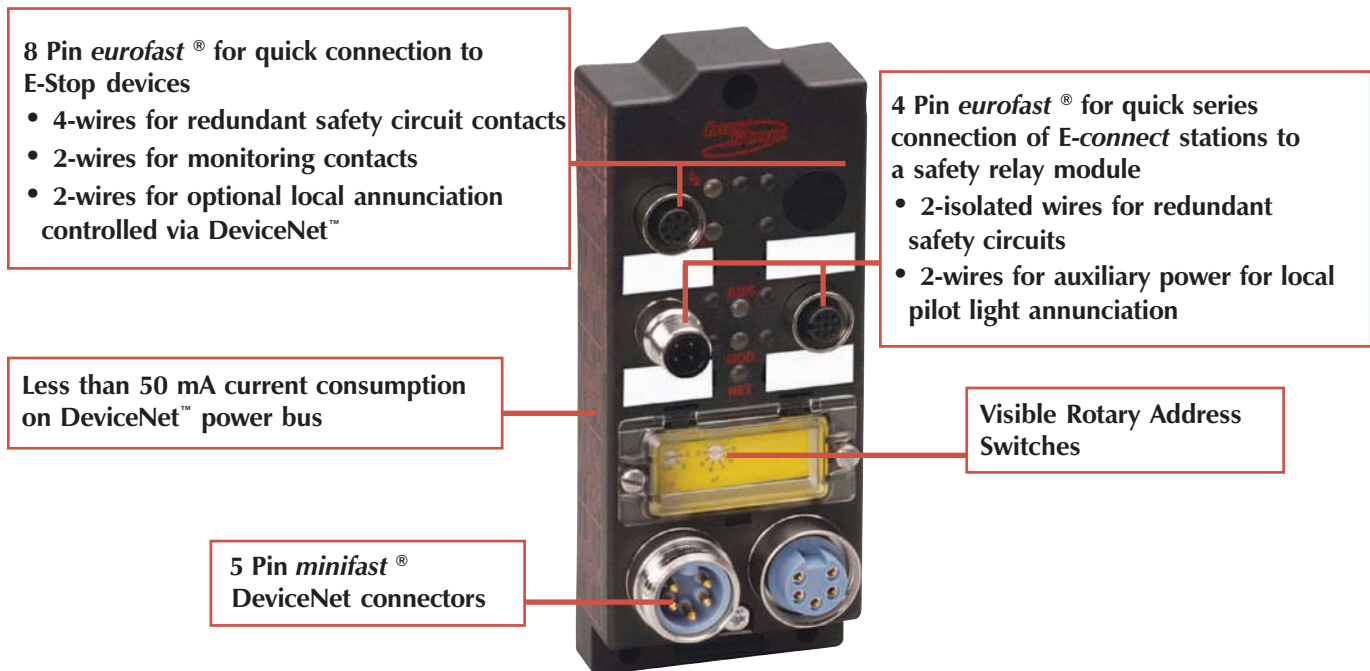

### Advantages

- Tremendous savings in startup and trouble shooting time
- DeviceNet PLC monitors the state of the safety switch
- Easy to integrate into any DeviceNet station
- Provides quick connection to standard e-stop devices and safety relays

The information contained in this publication is general in nature and is for educational purposes. Each application is unique. It is the responsibility of the user to ensure all-applicable jurisdictional codes and regulations are satisfied, and that installation and maintenance instructions are followed.

## Series E-connect

The series E-connect system provides quick, basic e-stop with a total of only seven different components and cabling. The red cables, tees and mini connectors assemble quickly and can be maintained easily. Its only difference from a standard pipe and wire solution is that it is connectorized. It is still a true hard wired system; the pipe and wire have simply been replaced with red connectorized cable.

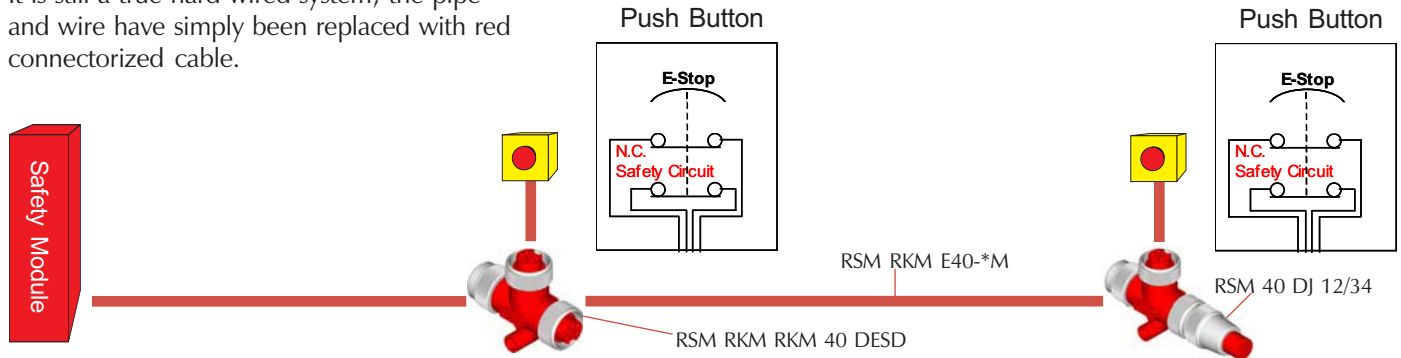

## Series E-connect with Monitoring and Annunciation

The second system adds DeviceNet™ in order to monitor where the e-stop occurred and provide an output for local annunciation. The safety circuit is still a true hard wired system; it is passing through and uses an “E-connect” station as a connectorized junction.

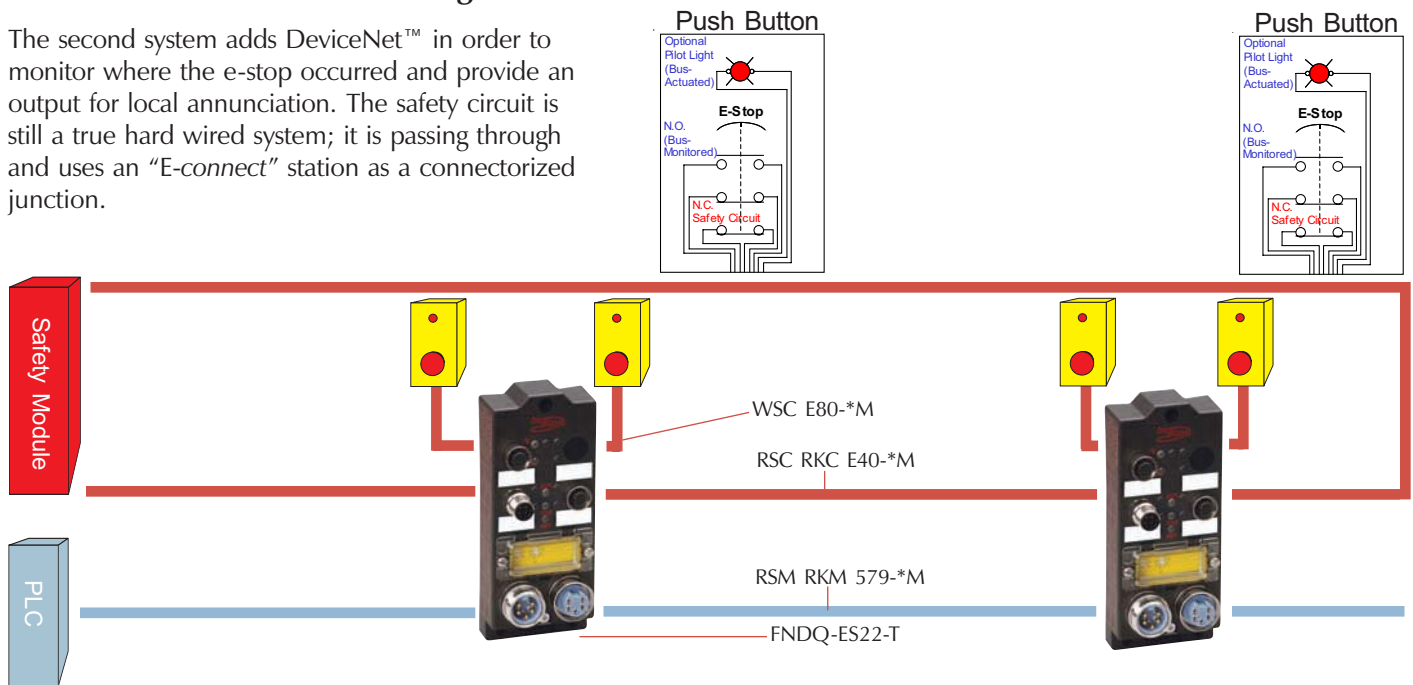

## Dedicated E-connect

This method offers easy connectorization for safety devices. Each set of safety contacts in the e-stop device connects to a single set of inputs on the safety relay. Two door safety switches are connected by 4-wire cordsets to the VB2 “Y” junction and an 8-wire cordset connects to two safety modules or a tandem module. All circuits remain isolated.

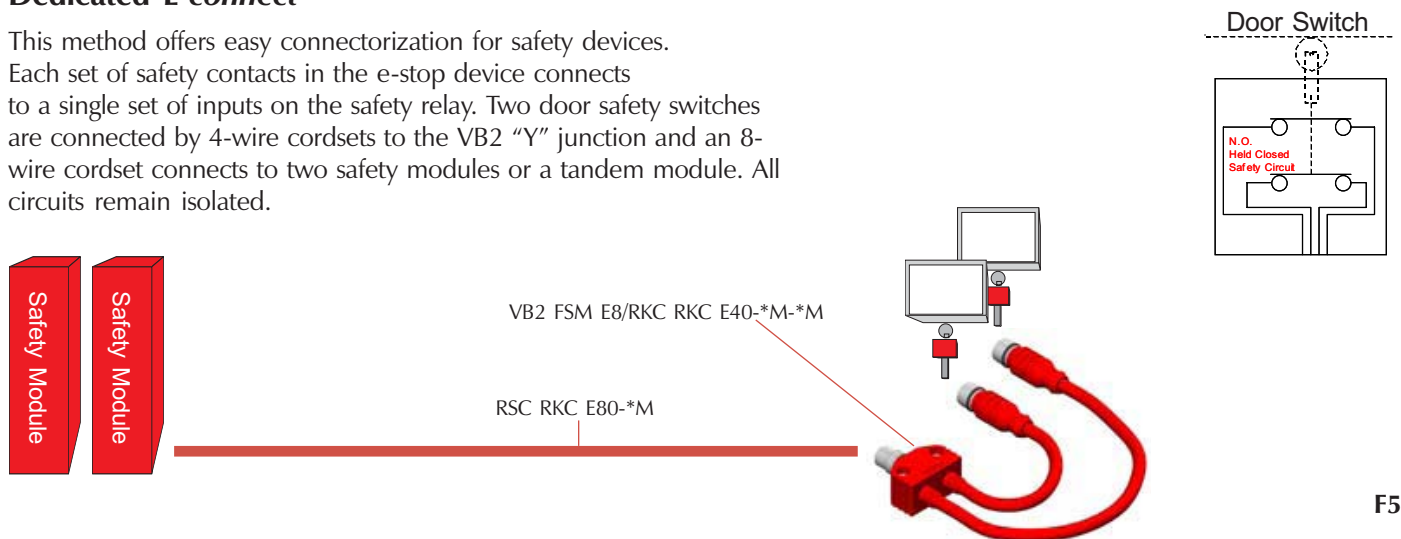

**E-connect™, Cable Specifications**

- Provides E-line Connection from Safety Module to Field Device
- Provides Drop to E-Stop Device
- Red PCV Jackets

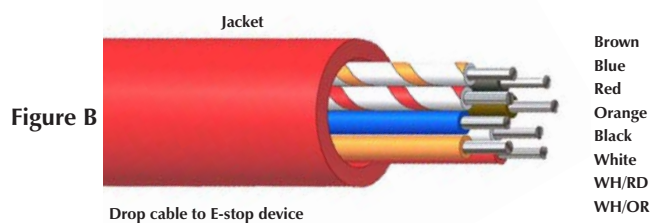
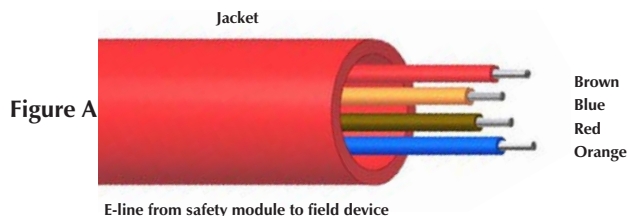

Type	Approvals	Power Pair		Outer Jacket	Bulk Cable Part Number / Weight/300 M	Figure
		AWG Color Code	DCR (/1000 feet) Insulation	Material Color Nominal O.D.		
<b>E40</b> AWM 2517 105°C 300 Volts	NEC PLTC/ITC/CL2 CEC AWM-I/II A/B FT4	4/18 AWG BN/BU/RD/OR	6.5 Ohms PVC	PVC Red 7.2 mm (.285 in)	RB50896-*M 58 lbs.	A
<b>E46</b> AWM 2517 105°C 300 Volts	NEC PLTC/ITC/CL2 CEC AWM-I/II A/B FT4	4/16 AWG BN/BU/RD/OR	4.3 Ohms PVC	PVC Red 8.4 mm (.330 in)	RB50925-*M 81 lbs.	A
<b>E80</b> AWM 2517 105°C 300 Volts	NEC CL2 CEC AWM-I/II A/B FT4	8/24 BN/BU/RD/OR/BK/WH/ WH, RD/WH, OR	27.7 Ohms PVC	PVC Red 5.7 mm (.224 in)	RB50897-*M 36 lbs.	B

\* Indicates length in meters.









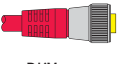

x Indicates cable type.

Standard cable lengths are 30, 75, 150, 225 and 300 meters. Consult factory for other lengths.

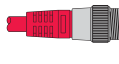
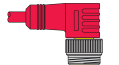
+ See page A6 for *flexlife*® and *weldlife* performance.

For stainless steel coupling nuts change part number RSM ... to RSV, WSM ... to WSV.

**E-connect™, Cable/Cordset Selection Matrix**

		<i>minifast</i> ®				<i>eurofast</i> ® (Thin/Mid Only)
		Pin (Male)		Socket (Female)		Pin (Male)
		1 	2 	3 	4 	5 
		RSM	WSM	RKM	WKM	RSC
	Bare	RSM Exx-*M	WSM Exx-*M	RKM Exx-*M	WKM Exx-*M	RSC Exx-*M
<i>minifast</i>	Pin (Male)	1  RSM RSM RSM Exx-*M	RSM WSM Exx-*M	RSM RKM Exx-*M	RSM WKM Exx-*M	RSM RSC Exx-*M
	Socket (Female)	2  WSM	WSM WSM Exx-*M	WSM RKM Exx-*M	WSM WKM Exx-*M	WSM RSC Exx-*M
	Socket (Female)	3  RKM		RKM RKM Exx-*M	RKM WKM Exx-*M	RKM RSC Exx-*M
	Socket (Female)	4  WKM			WKM WKM Exx-*M	WKM RSC Exx-*M
<i>eurofast</i> (Thin/Mid Only)	Pin (Male)	5  RSC				RSC RSC Exx-*M
	Pin (Male)	6  WSC				
	Socket (Female)	7  RKC				
	Socket (Female)	8  WKC				

See pages F56 - F57 for dimensional drawings.



\* Indicates length in meters.

x Indicates cable type.

Refer to the Cordset Builder at [www.turck.com](http://www.turck.com) for assistance with cordset/cable combinations.

Standard cable lengths are 0.3, 0.5, 1.0, 2.0, 2.5, 3.0, 3.5, 4.0, 5.0, 6.0, 8.0, 10, 15....50 Meters. Consult factory for other lengths.

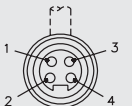
For stainless steel coupling nuts change part number RSM ... to RSV, WSM ... to WSV.

<i>minifast</i>	Pinouts	<i>minifast</i>
<b>Female</b> 	1. Bare (Shield Drain Wire) 2. Red (+ Voltage) 3. Black (- Voltage) 4. White (CAN_H)	<b>Male</b> 

**E-connect™, Cable/Cordset Selection Matrix**

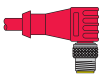
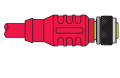
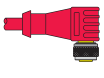
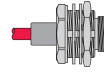
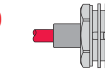
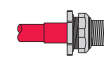
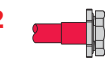
<i>eurofast</i> ® (Thin/Mid Only)			<i>minifast</i> ® Bulkhead		<i>eurofast</i> Bulkhead (Thin Only)	
Pin (Male)	Socket (Female)		Pin (Male)	Socket (Female)	Pin (Male)	Socket (Female)
<b>6</b>  WSC	<b>7</b>  RKC	<b>8</b>  WKC	<b>9</b>  RSFP	<b>10</b>  RKFP	<b>11</b>  FSFD	<b>12</b>  FKFD
WSC Exx-*M	RKC Exx-*M	WKC Exx-*M	RSFP Exx-*M	RKFP Exx-*M	FSFD Exx-*M	FKFD Exx-*M
RSM WSC Exx-*M	RSM RKC Exx-*M	RSM WKC Exx-*M	RSM RSFP Exx-*M	RSM RKFP Exx-*M	RSM FSFD Exx-*M	RSM FKFD Exx-*M
WSM WSC Exx-*M	WSM RKC Exx-*M	WSM WKC Exx-*M	WSM RSFP Exx-*M	WSM RKFP Exx-*M	WSM FSFD Exx-*M	WSM FKFD Exx-*M
RKM WSC Exx-*M	RKM RKC Exx-*M	RKM WKC Exx-*M	RKM RSFP Exx-*M	RKM RKFP Exx-*M	RKM FSFD Exx-*M	RKM FKFD Exx-*M
WKM WSC Exx-*M	WKM RKC Exx-*M	WKM WKC Exx-*M	WKM RSFP Exx-*M	WKM RKFP Exx-*M	WKM FSFD Exx-*M	WKM FKFD Exx-*M
RSC WSC Exx-*M	RSC RKC Exx-*M	RSC WKC Exx-*M	RSC RSFP Exx-*M	RSC RKFP Exx-*M	RSC FSFD Exx-*M	RSC FKFD Exx-*M
WSC WSC Exx-*M	WSC RKC Exx-*M	WSC WKC Exx-*M	WSC RSFP Exx-*M	WSC RKFP Exx-*M	WSC FSFD Exx-*M	WSC FKFD Exx-*M
	RKC RKC Exx-*M	RKC WKC Exx-*M	RKC RSFP Exx-*M	RKC RKFP Exx-*M	RKC FSFD Exx-*M	RKC FKFD Exx-*M
		WKC WKC Exx-*M	WKC RSFP Exx-*M	WKC RKFP Exx-*M	WKC FSFD Exx-*M	WKC FKFD Exx-*M

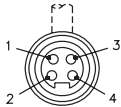
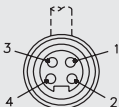
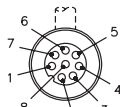
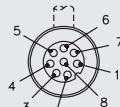
<i>minifast</i>	Pinouts	<i>minifast</i>	<i>eurofast</i>	Pinouts	<i>eurofast</i>
<b>Female</b> 	1. BN(+ AUX) 2. RD (E1L) 3. OR (E2L) 4. BU (- AUX)	<b>Male</b> 	<b>Male</b> 	1. BK (IN) 2. WH (OUT) 3. BN (AUX+) 4. RD (SC1) 5. WH/RD (SC1c) 6. OR (SC2) 7. WH/OR (SC2c) 8. BU (AUX-)	<b>Female</b> 

**E-connect™, minifast® Cordset and Receptacle Connector Dimensions**

**Specifications**

<b>Overmold:</b>	PUR (Polyurethane)
<b>Coupling Nut:</b>	Nickel Plated CuZn or Stainless Steel
<b>Contact Carrier:</b>	PUR (Polyurethane)
<b>Contacts:</b>	Gold Plated CuZn
<b>Protection:</b>	NEMA 1, 3, 4, 6P and IEC IP 67
<b>Rated Voltage:</b>	300 V
<b>Rated Current:</b>	9 A
<b>Ambient Temperature:</b>	-40° to +105°C (-40° to +221°F)

1

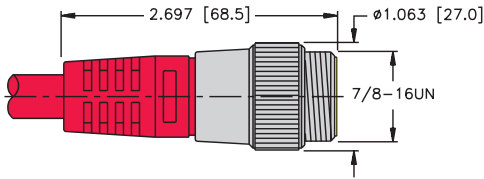

RSM ..

Pages F54 - F55

3

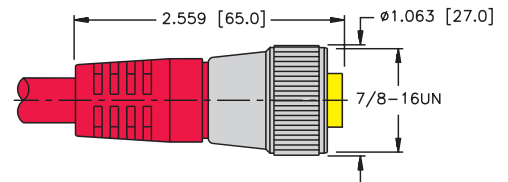

RKM ..

Pages F54 - F55

2

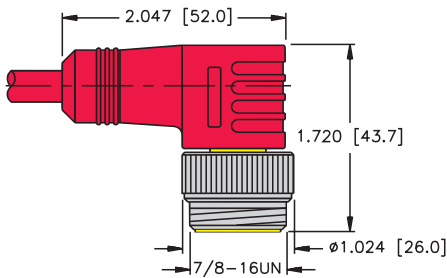

WSM ..

Pages F54 - F55

4

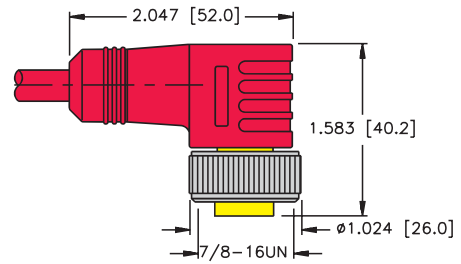

WKM ..

Pages F54 - F55

9

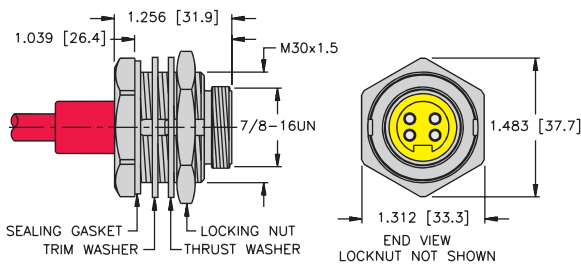

RSFP ..

Pages F54 - F55

10

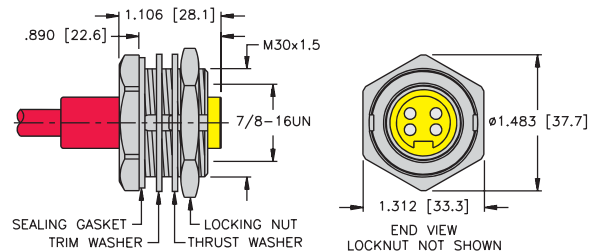

RKFP ..

Pages F54 - F55

**E-connect™, eurofast® Cordset and Receptacle Connector Dimensions**

**Specifications**

<b>Overmold:</b>	PUR (Polyurethane)
<b>Coupling Nut:</b>	Nickel Plated CuZn or Stainless Steel
<b>Contact Carrier:</b>	PUR (Polyurethane) or POM (Nylon)
<b>Contacts:</b>	Gold Plated CuZn
<b>Protection:</b>	NEMA 1, 3, 4, 6P and IEC IP 68
<b>Rated Voltage:</b>	250 V
<b>Rated Current:</b>	4 A
<b>Ambient Temperature:</b>	-40° to +105°C (-40° to +221°F)

**5**

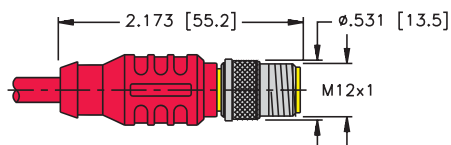

RSC ..

Pages F54 - F55

**7**

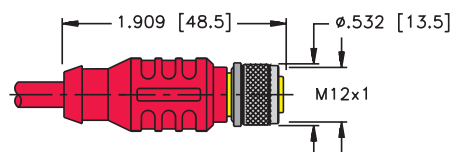

RKC ..

Pages F54 - F55

**6**

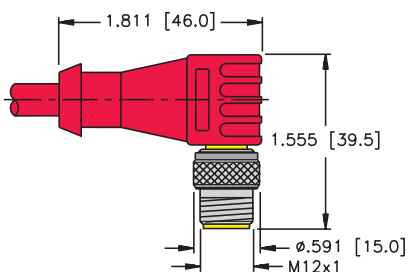

WSC ..

Pages F54 - F55

**8**

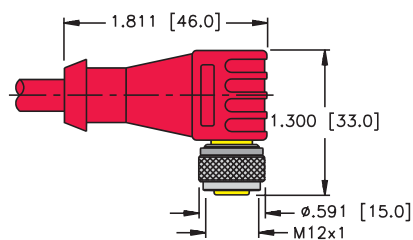

WKC ..

Pages F54 - F55

**11**

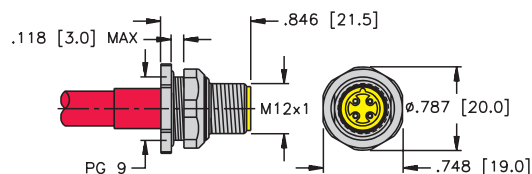

FSFD ..

Pages F54 - F55

**12**

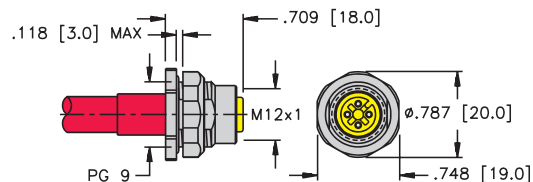

FKFD ..

Pages F54 - F55

**E-connect™, Tee**

- Provides Dual Interruptions to Auxiliary Power
- (7/8-16 UN) *minifast*® Connectors on Bus & Drop Lines

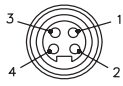

Housing	Part Number	Specs	Application	Pinouts
See Figure 1	RSM RKM RKM 40 DESD	TPU (Polyurethane) 250 V, 4 A -30° to 75°C	<ul style="list-style-type: none"> <li>• E &amp; M Dual Stop Drop Tee</li> <li>• Provides dual interruption to auxiliary power</li> <li>• Terminate with <i>minifast</i>® internal jumper</li> </ul>	<div style="display: flex; justify-content: space-around;"> <div style="text-align: center;"> <p><b>Male</b></p>  </div> <div style="text-align: center;"> <p><b>Female</b></p>  </div> </div>

DeviceNet

Standard housing material is nickel plated brass. "RSM RKM.."; "RSV RKV.." indicates stainless steel housing.

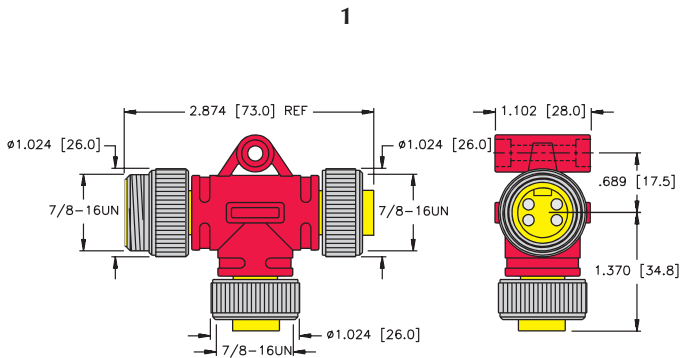

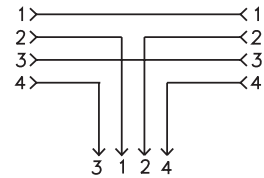

**Wiring Diagram**



**E-connect™, Terminating Resistor**

- Male *minifast*® Connector
- TPE (PUR) Overmold Body

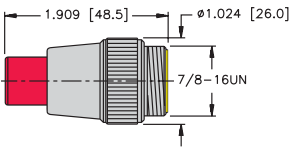

Housing	Part Number	Specs	Application	Pinout
	<b>RSM 40 DJ 12/34</b>	Nickel Plated Brass or Stainless Steel 300 V, 9 A -40 to +75°C IP 67	<ul style="list-style-type: none"> <li>• <i>minifast</i> with Dual Internal Jumper</li> <li>• Internally jumpered to complete dual</li> <li>• E &amp; M stop circuits</li> </ul>	<p><b>Male</b></p> 

## E-connect™, eurofast® Drop Junctions

- Creates a Drop or Branch from the Main Bus Line
- Cable Drop Lengths Available Up to a Maximum of 6 Meters



Housing	Part Number	Application	Wiring Diagram
See Figure 1	VB2 FSM E8/RKC RKC E40-*M-*M	<ul style="list-style-type: none"> <li>• VB2 Junction with Trunk Line</li> <li>• Reduced power and data branch</li> <li>• Maximum six meter branch</li> </ul>	

\* Indicates length in meters.

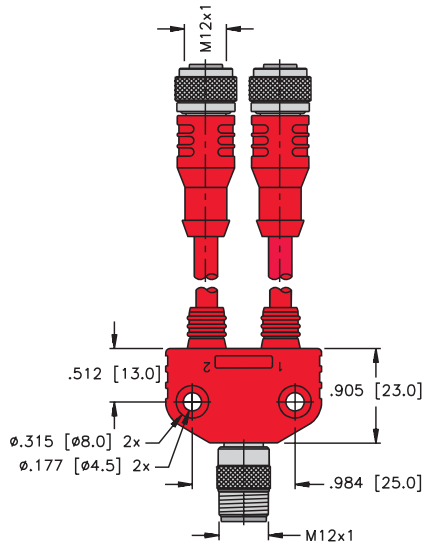

**E-Connect Stations**



- Rugged, Fully Potted Stations
- Monitor E-Stop Switches with DeviceNet
- IP 67, IP 68, IP 69K Protection
- Automatic Baud Rate Sensing

**Electrical**

- Operating Current: <40 mA (from DeviceNet)
- Output Current: <500 mA per output (from Aux. Power)

**Power Distribution**

- Inputs: Auxiliary power supply
- Outputs: Auxiliary power supply

**Mechanical**

- Operating Temperature: -25 to +70°C (-13 to +158°F)
- Protection: NEMA 1,3,4,12,13 / IEC IP 67, IP 68, IP 69K
- Vibration: 50 g @ 10-500 Hz

**Material**

- Connectors: Nickel-plated brass (stainless steel available on request)
- Housing: Nylon 6 (other materials available on request)

**Diagnostics (Logical)**

- One bit in I/O table indicates status of Auxiliary Power Supply (APS)

**Diagnostics (Physical)**

- LEDs to indicate status of DeviceNet communication

FDNP-ES44-TC  
 FDNP-ES88-TC  
 FDNP-ES88-TT

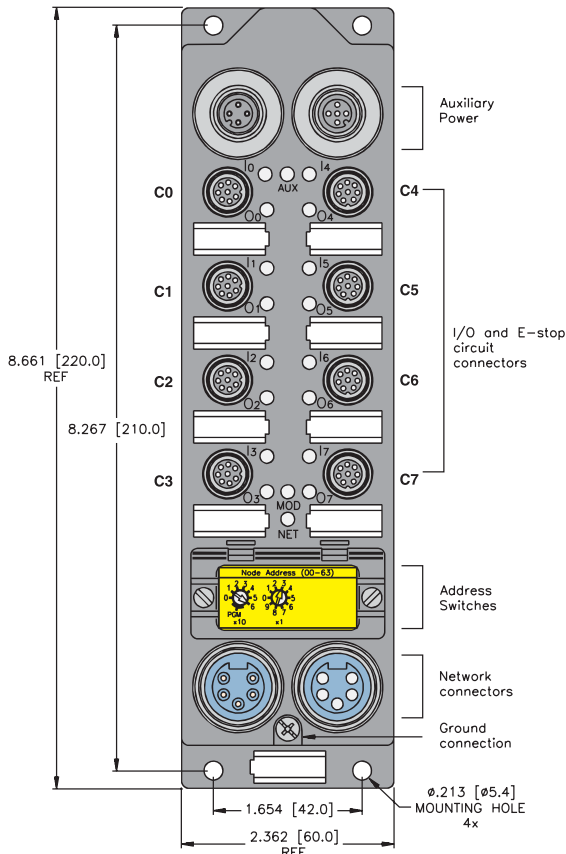

**Aux. Power eurofast Pinout**

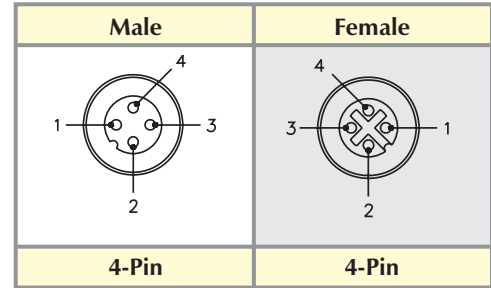

**Aux. Power minifast Pinout**

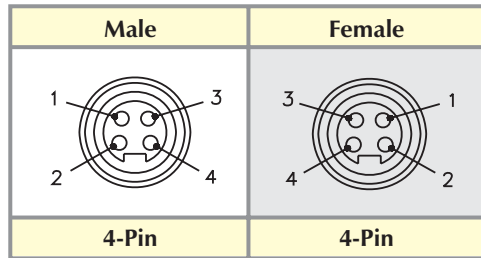

...-TT

**DeviceNet minifast Pinout**

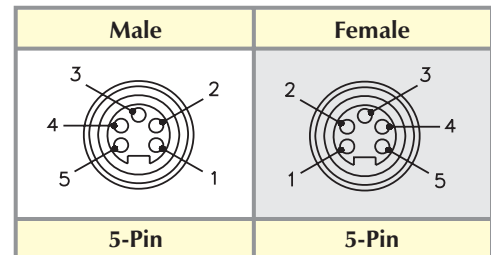

Part Number	Inputs								Outputs					Data		
	Input Count	Connectors	Pinout	Inputs per Connector	Sensor Style	Group Diagnostics	Individual Diagnostics	Wire-Break Detection	Output Count	Connectors	Pinout	Outputs per Connector	Current	Individual Diagnostics	Wire-Break Detection	I/O Map
FDNP-ES44-TC	4	0-1, 4-5	E8	1	E-Stop				4	0-1, 4-5	E8	1	0.5 A			2
FDNP-ES88-TC	8	0-7	E8	1	E-Stop				8	0-7	E8	1	0.5 A			1
FDNP-ES88-TT	8	0-7	E8	1	E-Stop				8	0-7	E8	1	0.5 A			1

## Input/Output Connectors

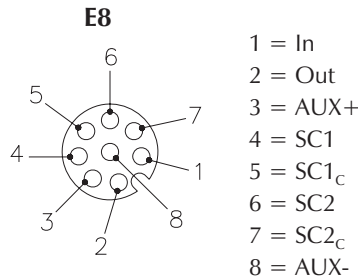

**Mating cordset:**  
RSC RKC E80-\*M

**I/O Data Map 1**

	Byte	Bit 7	Bit 6	Bit 5	Bit 4	Bit 3	Bit 2	Bit 1	Bit 0
<b>In</b>	0	I-7	I-6	I-5	I-4	I-3	I-2	I-1	I-0
	1	APS	-	-	-	-	-	-	-
<b>Out</b>	0	0-7	0-6	0-5	0-4	0-3	0-2	0-1	0-0

**I/O Data Map 2**

	Byte	Bit 7	Bit 6	Bit 5	Bit 4	Bit 3	Bit 2	Bit 1	Bit 0
<b>In</b>	0	APS	-	-	-	I-3	I-2	I-1	I-0
<b>Out</b>	0	-	-	-	-	0-3	0-2	0-1	0-0

E-Connect Stations



FDNQ-ES11-T  
FDNQ-ES22-T



- Rugged, Fully Potted Stations
- IP 67, IP 68, IP 69K Protection
- Monitor E-Stop Switches with DeviceNet
- Automatic Baud Rate Sensing

**Electrical**

- Operating Current: <50 mA (from DeviceNet)
- Output Current: <500 mA per output (from Auxiliary power supply)

**Power Distribution**

- Inputs: Auxiliary power supply
- Outputs: Auxiliary power supply

**Mechanical**

- Operating Temperature: -25 to +70°C (-13 to +158°F)
- Protection: NEMA 1,3,4,12,13 / IEC IP 67, IP 68, IP 69K
- Vibration: 50 g @ 10-500 Hz

**Material**

- Connectors: Nickel-plated brass (stainless steel available on request)
- Housing: Nylon 6 (other materials available on request)

**Diagnostics (Logical)**

- One bit in I/O table indicates status of Auxiliary Power Supply (APS)

**Diagnostics (Physical)**

- LEDs to indicate status of DeviceNet communication

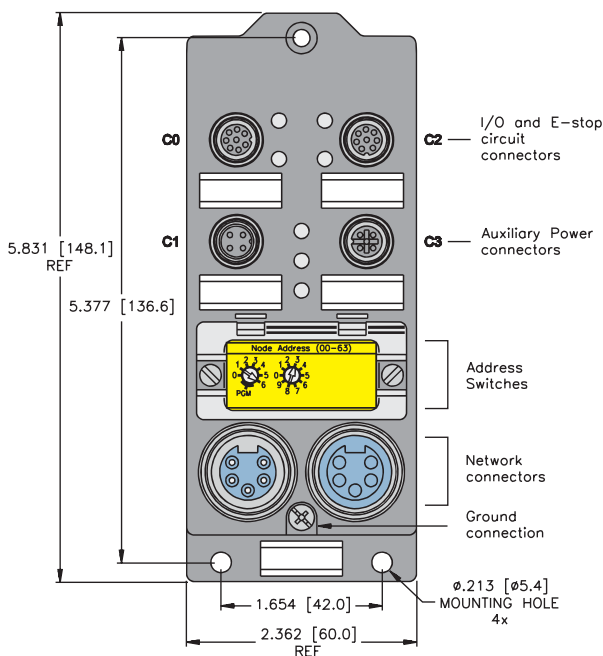

**Aux. Power eurofast Pinout**

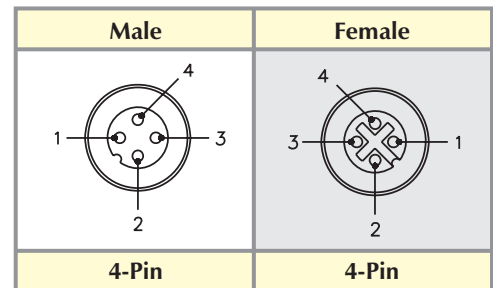

- 1 =  $V_{AUX+}$
- 2 =  $SC_1$
- 3 =  $SC_2$
- 4 =  $V_{AUX-}$

**DeviceNet minifast Pinout**

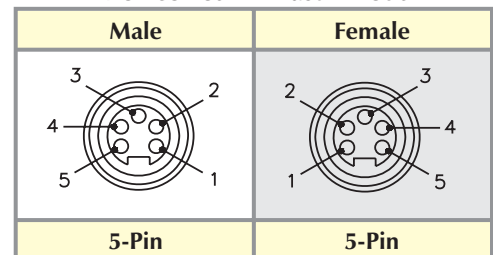

- 1 = Shield
- 2 = V+
- 3 = V-
- 4 = CAN\_H
- 5 = CAN\_L

Part Number	Inputs								Outputs					Data		
	Input Count	Connectors	Pinout	Inputs per Connector	Sensor Style	Group Diagnostics	Individual Diagnostics	Wire-Break Detection	Output Count	Connectors	Pinout	Outputs per Connector	Current	Individual Diagnostics	Wire-Break Detection	I/O Map
FDNQ-ES11-T	1	0	E8	1	E-Stop				1	0	E8	1	0.5 A			1
FDNQ-ES22-T	2	0, 2	E8	1	E-Stop				2	0, 2	E8	1	0.5 A			2

## Input/Output Connectors

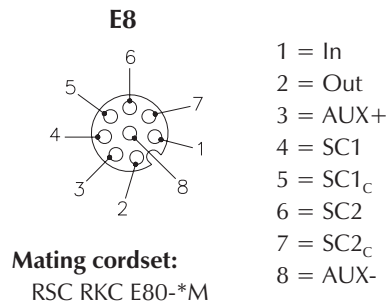

**I/O Data Map 1**

	Byte	Bit 7	Bit 6	Bit 5	Bit 4	Bit 3	Bit 2	Bit 1	Bit 0
<b>In</b>	0	APS	-	-	-	-	-	-	I-0
<b>Out</b>	0	-	-	-	-	-	-	-	0-0

**I/O Data Map 2**

	Byte	Bit 7	Bit 6	Bit 5	Bit 4	Bit 3	Bit 2	Bit 1	Bit 0
<b>In</b>	0	APS	-	-	-	-	-	I-1	I-0
<b>Out</b>	0	-	-	-	-	-	-	0-1	0-0