

Multiturn Type 5860 , DeviceNet™



High IP



High shaft load
capacity



Shock/vibra-
tion resistant



Short-circuit
proof



Reverse polarity
protection

Compact and Rugged:

- Minimal installation depth
- High shock and vibration values
- Very compact (only 87.8 mm installation depth); Ideal for dynamic applications thanks to its non-contact multiturn stage



DeviceNet.

Versatile and Easy:

- Many options (no need for adapter sleeves)
- Fully programmable
- Integrated Fieldbus node with T-Coupler

Fast and safe:

- Certificated connection technology
- Plug & Play cable assemblies
- Long service life thanks to high shock and vibration resistance
- Diagnostics and alarm functions
- also available as explosion proof Zones 2 and 22

Mechanical characteristics:

Speed ¹⁾ :	max. 6000 min ⁻¹
Rotor moment of inertia:	approx. 1.8 x 10 ⁻⁶ kgm ²
Starting torque:	< 0.01 Nm
Load capacity of shaft at shaft extension ³⁾ :	radial: 80 N, axial: 40 N
Weight:	approx. 0.7 kg
Protection acc. to EN 60529:	IP65
EX approval for hazardous areas:	optional zone 2 and 22
Working temperature:	-20° C ... +80 °C ²⁾
Shaft:	stainless steel
Shock resistance acc. to DIN-IEC 68-2-27:	2500 m/s ² , 6 ms
Vibration resistance acc. to DIN-IEC 68-2-6:	100 m/s ² , 10 ... 2000 Hz

¹⁾ For continuous operation 3000 min⁻¹ at the max. temperature

²⁾ Non-condensing
³⁾ Solid shaft version

Electrical characteristics:

Supply voltage (U _B):	10 ... 30 V DC
Current consumption:	max. 0.29 A
Recommended fuse:	T 0,315 A
Divisions:	up to 8192 (13 bits) per revolution, 4096 (12 bits) revolutions
Linearity:	± 1/2 LSB (±1 LSB at resolution 13, 14, 25 Bit)
Code:	Binary
Interface:	CAN HIGH-Speed to ISO/DIS 11898, Basic and Full-CAN; CAN specification 2.0 B (11 and 29 Bit Identifier)
Protocols:	DeviceNet™ Profile for Encoder Release V 2.0
Baud rate:	programmable via DIP switches 10 ... 1000 Kbits/s CAN DNET 125/250/500 kBit/s
Basic identifier/node number:	programmable via DIP switches
Conforms to CE requirements acc. to EN 61000-6-1, EN 61000-6-4 and EN 61000-6-3	
Performance against magnetic influence acc. to EN61000-4, 8, severity of inspection 5	
UL certified	File 224618
RoHS compliant acc. to EU guideline 2002/95/EG	

Multiturn Type 5860 , DeviceNet™

DeviceNet™ Encoder Profile:

General description:

The DeviceNet™ Device Profile describes the functionality of the communication and of that part of the DeviceNet™ fieldbus system specific to the manufacturer. The Encoder Profile applies to encoders and defines the individual objects independently of the manufacturer. In addition the profile makes provision for additional extended functions specific to the manufacturer.

The following parameters can be programmed:

- Direction of rotation
- Scaling factor
 - Number of pulses/rotation 1 ... 8192
 - Total resolution
- Number of revolutions 1 ... 4096
- Preset value
- Diagnostics mode

The following functionality is integrated:

- Galvanic isolation of the Fieldbus-stage with DC/DC converter
- Addressing via DIP switches or software
- Diagnostics LED network and mode
- Baud rate 125, 250 and 500 kbit/s programmable via DIP switches
- Node address 0 ... 63 and baud rate programmable via DIP switches
- Polled mode
- Cyclic mode
- Change of state mode (COS)
- Combination of Polled mode and Cyclic mode
- Combination of Polled mode and COS mode
- Offline connection set
- Device heartbeat

“Out of box” Configuration

- MAC-ID and Baud rate preset value
MAC-ID = 63
- Baud rate = 125 kBit/s
- 2 I/O Assembly
Position value
Position value and status

Fieldbus encoders can be used in the following applications:

cranes, agricultural vehicles,
special-purposes vehicles,
industrial automation

Elevators, construction machines,

Terminal assignment M12:

Bus in:

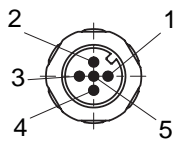

Signal :	DRAIN	+ V DC	- V DC	CAN_H	CAN_L
Pin:	1	2	3	4	5
	GY	RD	BK	WH	BU

Bus out:

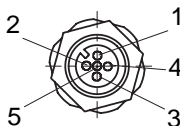

Signal :	DRAIN	+ V DC	- V DC	CAN_H	CAN_L
Pin:	1	2	3	4	5
	GY	RD	BK	WH	BU

Multiturn Type 5860 , DeviceNet™

Dimensions:

Synchro flange

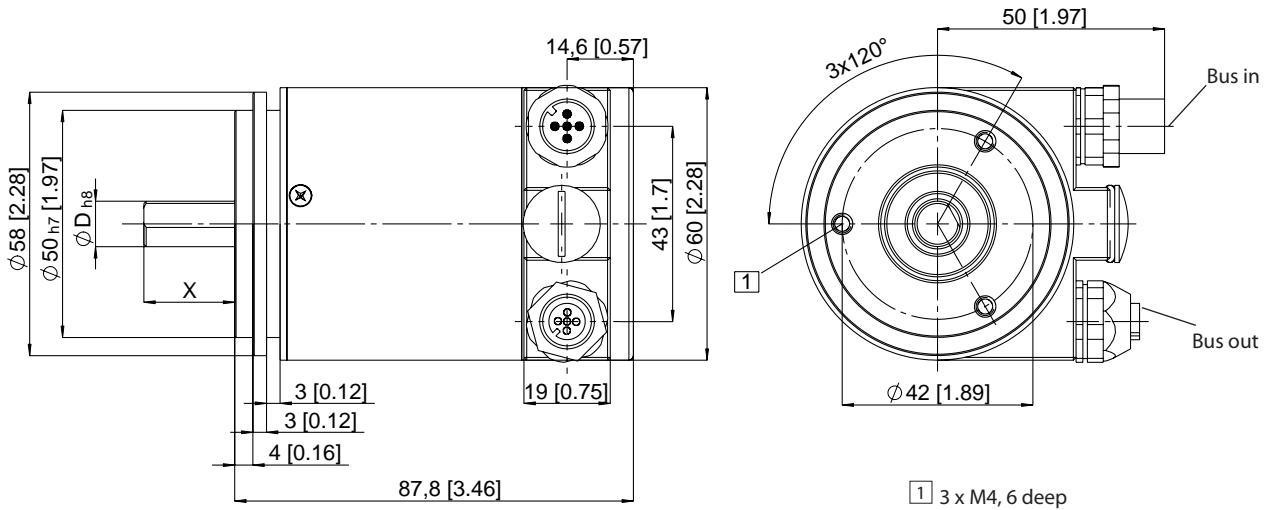

Clamping flange

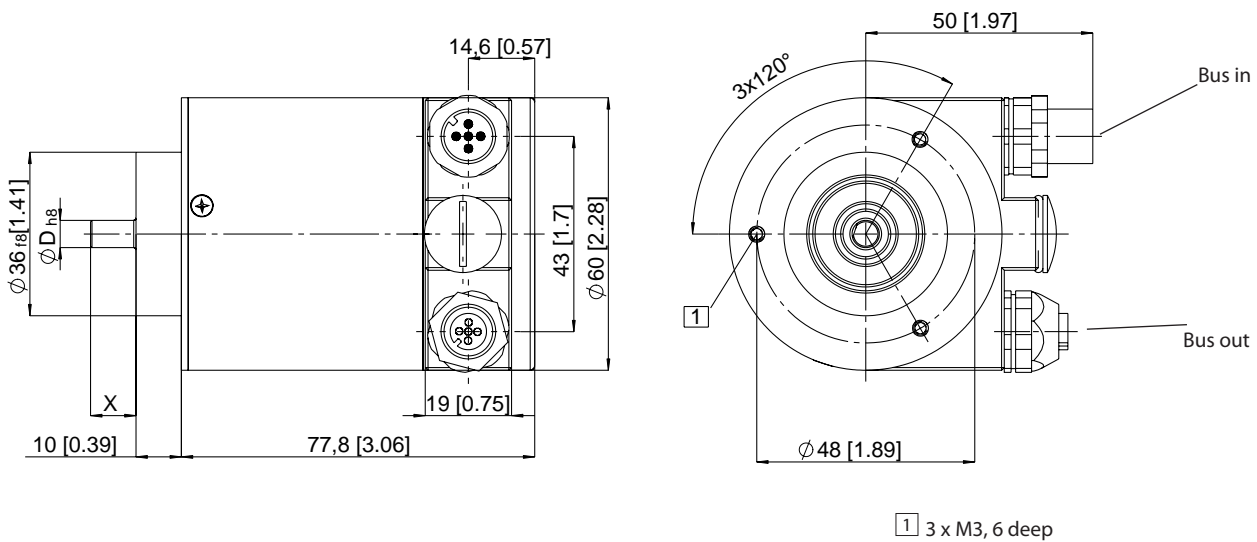

Suitable cable diameters:

Supply voltage, cable diameter 4.5 ... 6.5 mm

Data transmission line, cable diameter 8 ... 10 mm

Multiturn Type 5860 , DeviceNet™

Dimensions blind hollow shaft version:

Blind hollow shaft version
flat flange with spring element

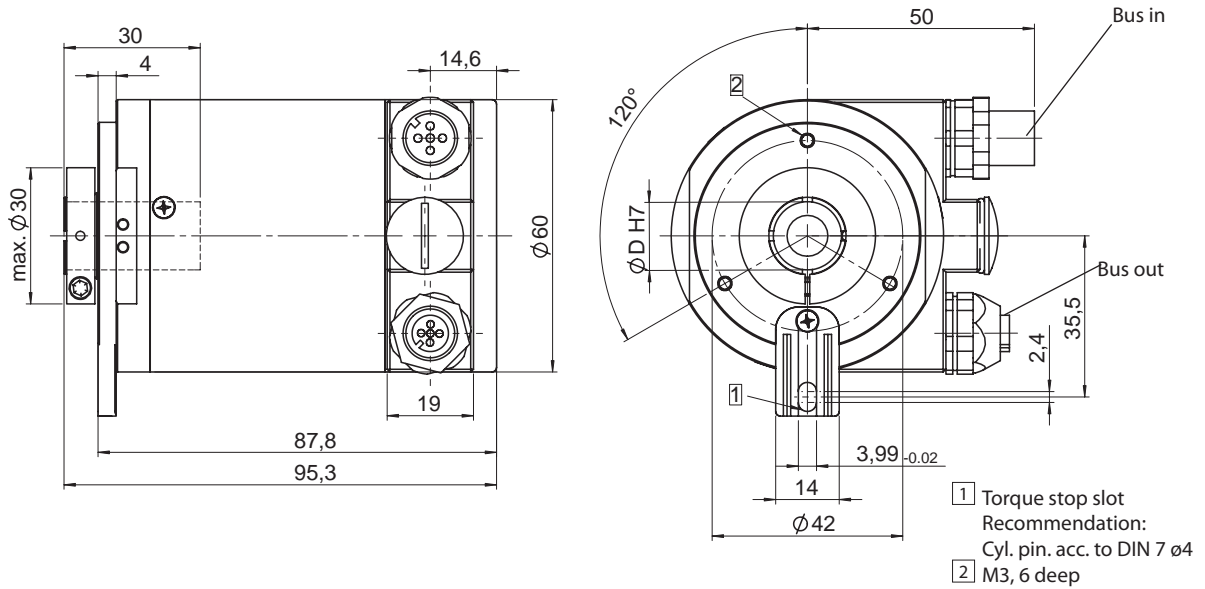

Blind hollow shaft version
Flat flange with double-winged stator coupling

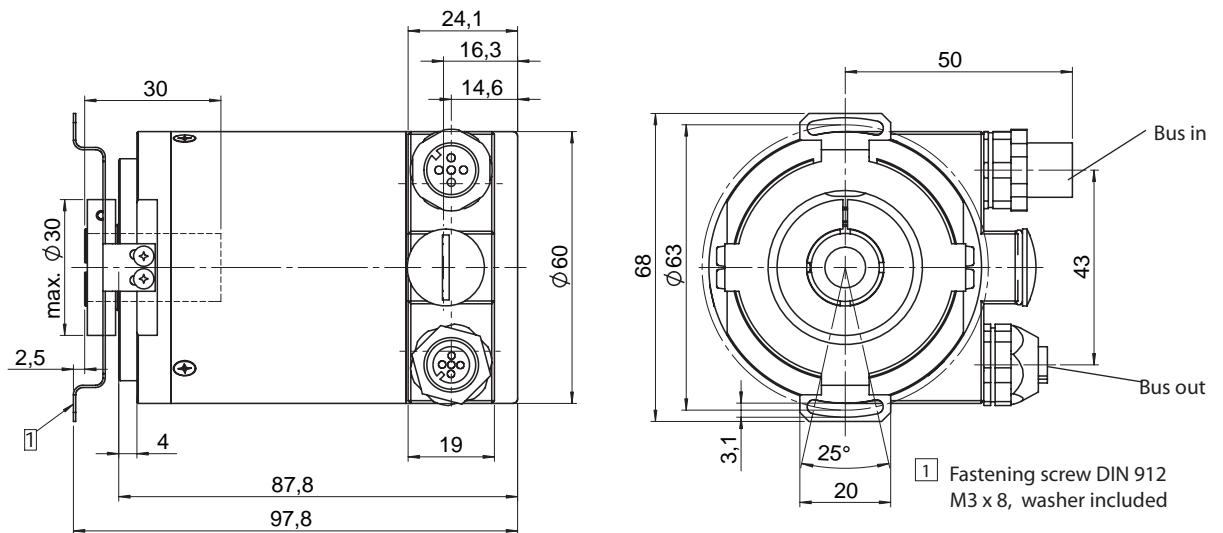

Multiturn Type 5860, DeviceNet™

TURCK is working consistently on high integration of all units and intelligent sensing systems. The basics of our encoders are two patented technologies:

Patented Integrative Technology®:

Integrative Technology, developed and patented by TURCK, is a package of measures that ensures compact construction, high signal quality, high shock resistance - up to 2500 m/s², high reliability and a high level of immunity to EMC.

This is achieved using an Opto ASIC, a multilayer board and an especially shock resistant and space-saving method of mounting the sensor unit. In addition the use of a highly optimized interface ASIC ensures the integration of several hundred individual components. Components that had previously been needed to balance the system, such as balancing potentiometers, can be dispensed with.

Patented Intelligent-Sensing-Technology (IST)®

An innovative principle of operation based on a non-contact electronic multiturn stage overcomes system disadvantages previously associated with encoders that had mechanical gears or with traditional electronic gear technology.

Advantages:

- High operational reliability
- Logic filter and innovative principle of operation compensate for high EMC interference
- Free from wear

Order code:

T8.5860.XX XX.X001

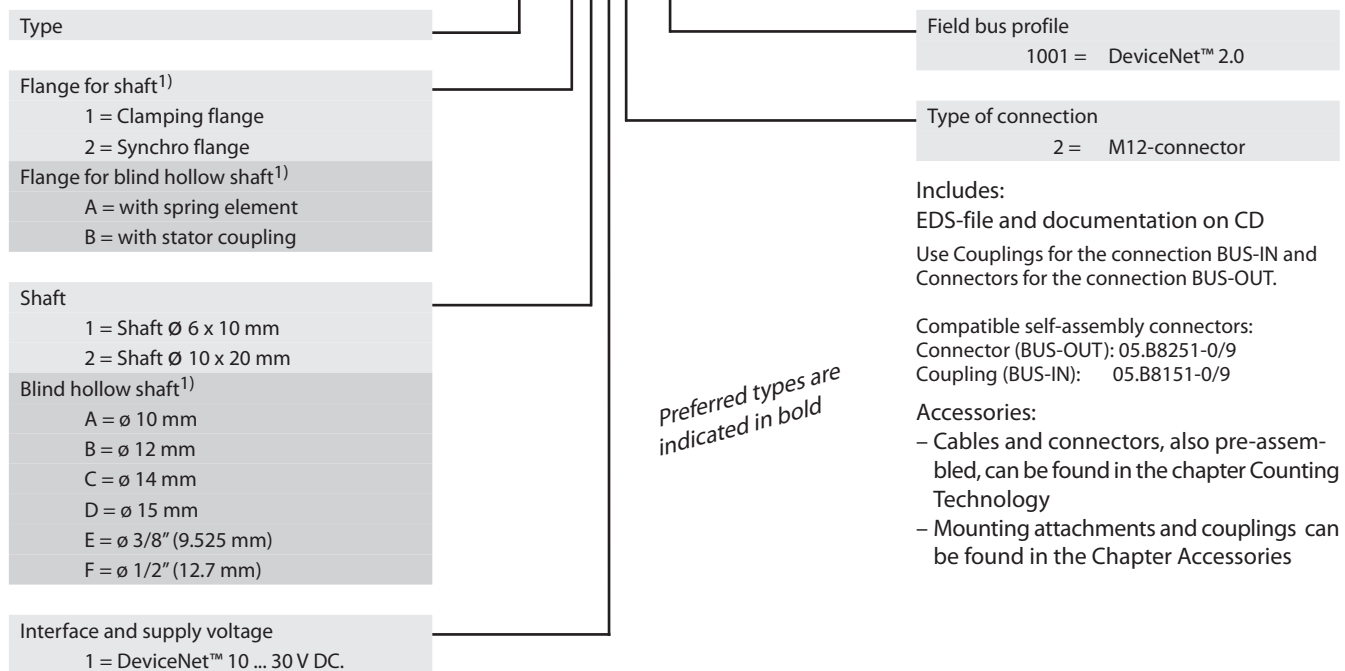

Includes:

EDS-file and documentation on CD
Use Couplings for the connection BUS-IN and Connectors for the connection BUS-OUT.

Compatible self-assembly connectors:
Connector (BUS-OUT): 05.B8251-0/9
Coupling (BUS-IN): 05.B8151-0/9

Accessories:

- Cables and connectors, also pre-assembled, can be found in the chapter Counting Technology
- Mounting attachments and couplings can be found in the Chapter Accessories

¹⁾ Figures and letters can not be combined