

DeviceNet™ Power Guide

TURCK
works

Industrial
Automation

DeviceNet™ Power Guide Rev 1.1



Overview:

DeviceNet has many advantages over point to point wiring. One main advantage is that the network can carry power to the input devices. This feature reduces the number of cables and simplifies the overall design. However, since the cable carries power over long distances, voltage drop and current limitations need to be considered in the design. This Guide discusses the current and voltage limits, and presents a simple way to design a system.

Design Considerations:

There are two limits that need to be considered when designing DeviceNet power:

- 1) Current Limits
- 2) Voltage Drop Limits

Current Limits

The first design consideration is the current limitation on the cable and connectors. This is pretty straightforward. Consult the manufacturer for this information. Typically:

- Trunk related components are rated at over 8 Amps (mini connectors)
- Drop cordsets are only rated to 4 Amps (eurofast connectors)
- NEC Class II situations are limited to 4 Amps

What does this mean? That depends on your interpretation of the specifications and on your particular needs. Typically, most designs limit the current in each cable to either 4 or 8 Amps. The two common approaches are:

- 1) Design to a 4-Amp limit in each leg.
- 2) Design to an 8-Amp limit in each leg. [When using this approach, you should use trunk or mid-size cable and mini-style connectors throughout.]

NEC Requirements

Many DeviceNet cables are considered Class II. The National Electric Code (NEC) limits Class II cables to 100VA. If the DeviceNet cable is considered building wiring, it will need to be powered by a Class II rated power supply. A Class II power supply typically limits available current to 4 Amps. If the DeviceNet cable is Class I rated, the current is only limited by the manufacturers cable rating.

Suggestion: If you are uncertain about the 4 or 8-Amp limit, design the system first with the 4-Amp limit. Once this is completed, you will have a good feel if the 4-Amp limit is appropriate or if the 8-Amp system would work better.

What exactly is a 4 Amp limit?

A 4 Amp limit means that each power segment will be fused at 4 Amps. **Diagram I** shows two network power segments, A and B. The total current from all devices on the A-side must be less than 4 Amps. Likewise the B-side total must be less than 4 Amps. The total current of both sides could be up to 8 Amps.

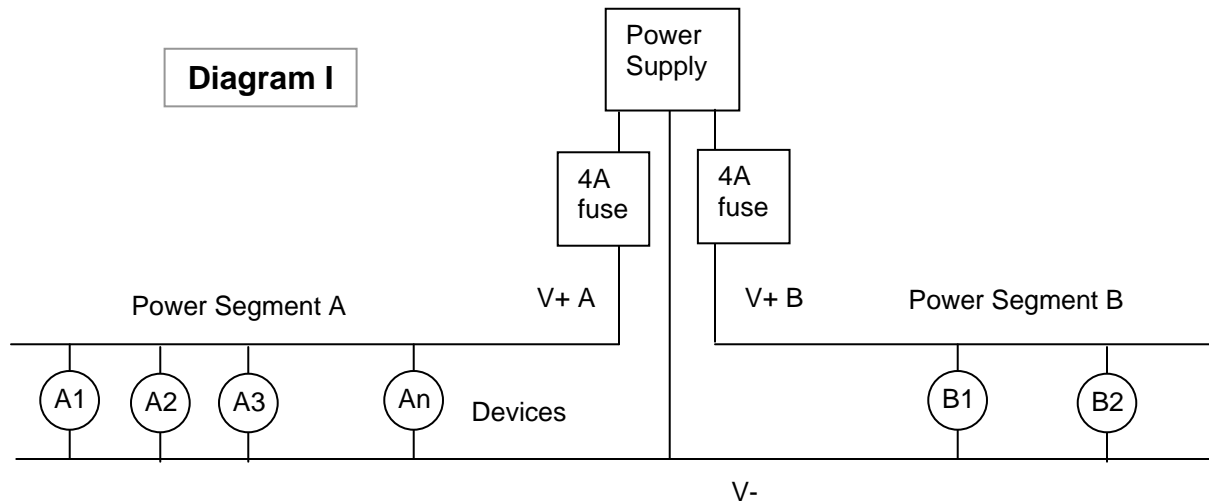

Current Rule: The current in any power segment is limited to 4 Amps (8 Amps in Class I).

Voltage Drop Limits – 5 Volts

DeviceNet transceivers (the integrated circuit which sends and receives electrical messages) can only communicate to other transceivers that are grounded to the same point. All DeviceNet transceivers should be grounded to within 5 Volts of one another. This is not a problem in short networks. All transceivers (nodes) are connected to the DeviceNet ground (V- or black) wire in the cable. The assumption is that one end of the DeviceNet cable ground is the same voltage as the other end. This starts to run into problems on longer networks.

On longer networks it is not enough to assume that each end of the ground wire is the same voltage. Resistance in the wire cannot be ignored. Use Ohm’s Law to determine the change in voltage from one end to the other.

Ohm’s Law: $V = I R$
I is the total current that flows through the DeviceNet ground (V- or Black)
R is the total resistance in the cable and connectors.

To simplify the voltage drop calculation, make a worst case approximation. Assume all stations are at the end of the network. Consequently, we calculate $V = IR$ only once.

Example:
 The network is 800 feet long and has a power supply at one end.
 The network has 5 devices; each draws 0.1 Amps.
 There are 10 connectors in the trunk @ 0.005 ohms per connector (each T has 2 trunk connectors).
 The network trunk cable has 3.25 Ohms/1000 feet.

$V = I \times R = 0.5 \text{ Amps} \times (800 \text{ feet} \times 3.25 \text{ Ohms}/1000\text{feet}) + .005 \times 10 \text{ contacts}$
 $V = 0.5 \text{ Amps} \times 2.65 \text{ Ohms}$
 $V = 1.33 \text{ Volts}$

5 Volt Ground Limit
 The ground voltage (using Ohm’s Law) cannot vary by more than 5 Volts on the entire network.

Standard Network Power Supply Segmentation Approaches:

Three network segmentation approaches are shown here. Segmenting a network means to determine how many separate V+ segments there are. The rest of the DeviceNet cable; Ground, CANH, CANL and Shield are continuous, with no fuses or interruptions to the entire network. Their lines are not shown in Diagram II.

Key:	N	= Node or DeviceNet Device
	PS	= Power supply
	F	= Fuse
	Solid line	= V+ (Red wire)

1 Power Segment [Diagram II] – This type of segment has a power supply at one end with a single fuse. This approach works fine for small systems that are typically less than 200 feet long and less than 4 Amps of total current.

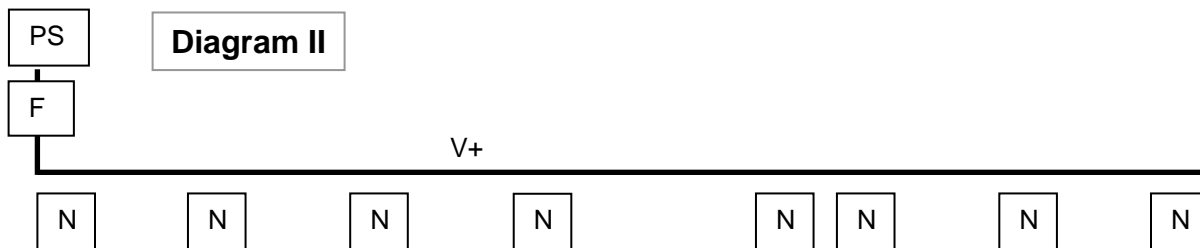

2 Power Segments [Diagram III] – This type of segment has a power supply in the center with two fuses, and is the most common approach. It allows you to build networks that are twice as long with twice as many nodes as the 1-segment approach. This approach is really just two of the 1-segment designs, with one segment going left and the other going right from the power supply.

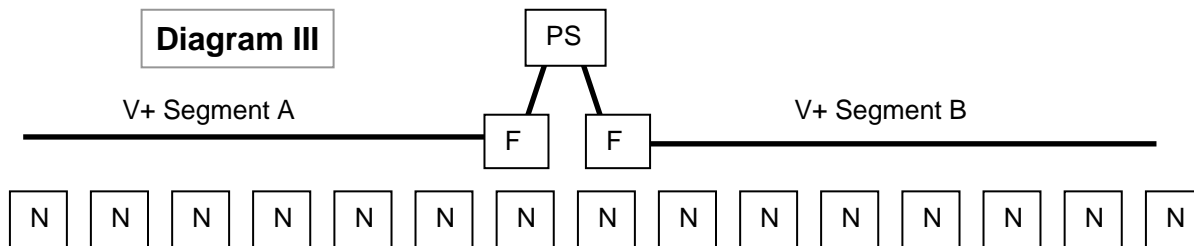

4 Power Segments [Diagram IV] – This approach doubles the 2-segment design. You can build networks twice as long with twice as many nodes as the 2-segment approach.

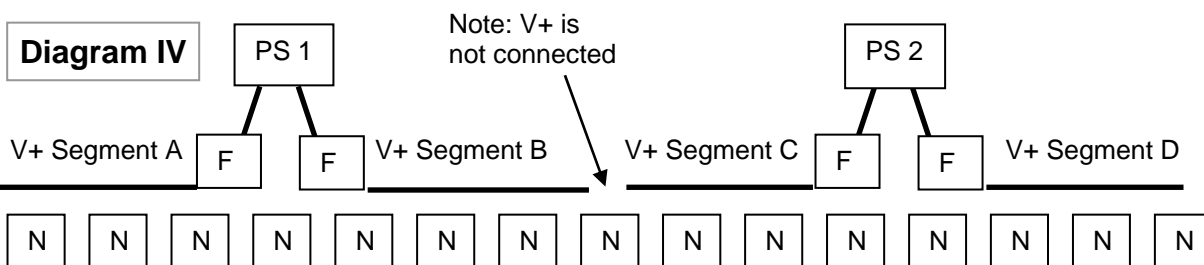

What about more segments? If 4 segments with 2 power supplies is still not enough, a repeater (Part No. REP-DN) is recommended. For example, an 8-segment system could be made using 4 segments, a repeater, and then another 4 segments. When using a repeater, each side of the repeater is completely separate electrically. Multiple repeaters may be used to design very large networks.

Step by Step Design Approach:

This simple approach will result in a network power design that is guaranteed to meet both the current and voltage drop limits.

Step 1) Decide what the Current Limit will be:

- 4 Amps (typical) - You can use Class II cable and eurofast drops.
- 8 Amps – Requires Class I rated cable and mini-style connectors.
[We will use 4 Amps in this example.]

Step 2) Assume a segmentation approach and layout the network.

In this example the typical 2-segment approach is assumed. There are 15 nodes on the network. Ideally, the power supply should be located in the center of the network. This brings up a good question. What is center? The ideal center is the power supply location that makes the voltage drop on both segments equal. Just pick a point near the center and sketch out the system. [Diagram V]

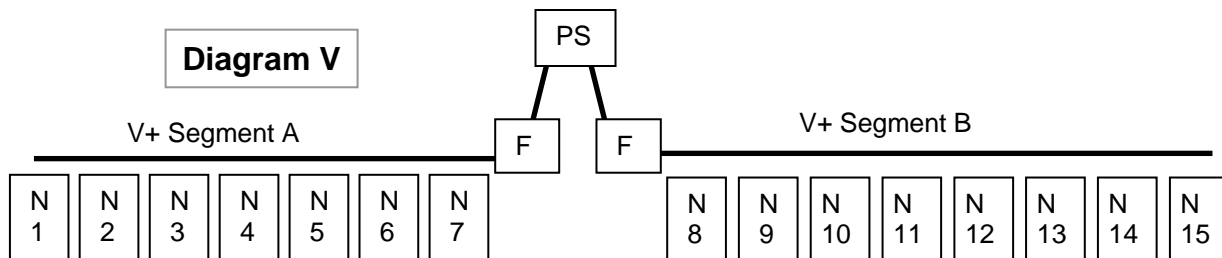

Step 3) Use the data sheets to determine the current draw at each location. This example uses the following nodes:

- The FDNL-S0800-T uses a maximum of 50 mA plus the sum of sensors at 35 mA each. (35 mA is per the sensor data sheets.) **50 mA + 35 mA x 8 = 330 mA**
- The FDNP-S0808G-TT uses a maximum of 75 mA plus the sum of sensors at 10 mA each. Do not include the outputs since they are powered from auxiliary power, not the DeviceNet power. **75 mA + 10 mA x 4 = 115 mA**
- The FDNP-XSG16-TT uses a maximum of 75 mA. Since all inputs and outputs are powered from auxiliary power, you do not add the sensor current for these stations.
- The FDNL-CSG88-T uses 100 mA plus the sum of all input and output currents on the attached pendant. There is no auxiliary power on this station. DeviceNet powers all inputs and outputs. Since the inputs are dry contacts, they require no additional power. (There is

actually about 3.2 mA of current flowing through the contact when it is closed. This current is included in the station's 100 mA budget). The output indicators on the pendant draw 40 mA each. **100 mA + 8 x 40 mA = 420 mA**

- 1747 SDN Scanner card draws 90 mA from DeviceNet power.

Step 4) Fill out a table [Table I] showing the current draw for each node and the segment it is on. Also, determine the length of each segment. **Segment A = 100 feet, B = 800 feet**

Table I

Node	Segment	Current in mA	Description
N 1	A	115	FDNP-S0808G-TT (with 4 world clamp proximity sensors)
N 2	A	75	FDNP-XSG16-TT (with 8 Part verification arrays each)
N 3	A	75	FDNP-XSG16-TT (with 8 Part verification arrays each)
N 4	A	75	FDNP-XSG16-TT (with 8 Part verification arrays each)
N 5	A	75	FDNP-XSG16-TT (with 8 Part verification arrays each)
N 6	A	75	FDNP-XSG16-TT (with 8 Part verification arrays each)
N 7	A	90	1747 SDN SLC 500 scanner card for PLC
N 8	B	330	FDNL-S0800-T (with 8 photoelectric sensors each)
N 9	B	330	FDNL-S0800-T (with 8 photoelectric sensors each)
N 10	B	330	FDNL-S0800-T (with 8 photoelectric sensors each)
N 11	B	330	FDNL-S0800-T (with 8 photoelectric sensors each)
N 12	B	420	FDNL-CSG88-T (with 8 pushbutton pendants each)
N 13	B	330	FDNL-S0800-T (with 8 photoelectric sensors each)
N 14	B	330	FDNL-S0800-T (with 8 photoelectric sensors each)
N 15	B	420	FDNL-CSG88-T (with 8 pushbutton pendants each)

Step 5) Use the numbers in **Table I** to calculate the voltage drop for V- on each segment. You can determine the voltage drop using Ohm's Law. The simple approach is to add the current on each segment and multiply it by the resistance on that segment. This is a worst case approximation, but it is fast and easy. For the first pass, use the Thick 579-cable resistance of 3.25 Ohms per 1000 feet.

For Segment A:

Total current is $115 + 75 \times 5 + 90 = 580$ mA

Total cable resistance is $3.25 \text{ Ohms}/1000 \text{ feet} \times 100 \text{ feet} + .005 \text{ Ohms per connector} \times 20 = .425$ Ohms

Total voltage drop is V- is $.58 \text{ A} \times .425 \text{ Ohms} = .25\text{V}$ (worst case)

This is great – way below the 5-Volt limit.

For Segment B:

Total current is $330 \times 6 + 420 \times 2 = 2.82$ Amps

Total cable resistance is $3.25 \text{ Ohms}/1000 \text{ feet} \times 800 \text{ feet} + .005 \text{ Ohms per connector} \times 20 = 2.7$ Ohms

Total voltage drop is $2.82\text{A} \times 2.7 \text{ Ohms} = 7.61$ Volts (worst case)

This is a problem – the voltage drop is greater than 5 Volts.

The following graph makes it easier to determine if the voltage drop limit has been exceeded.

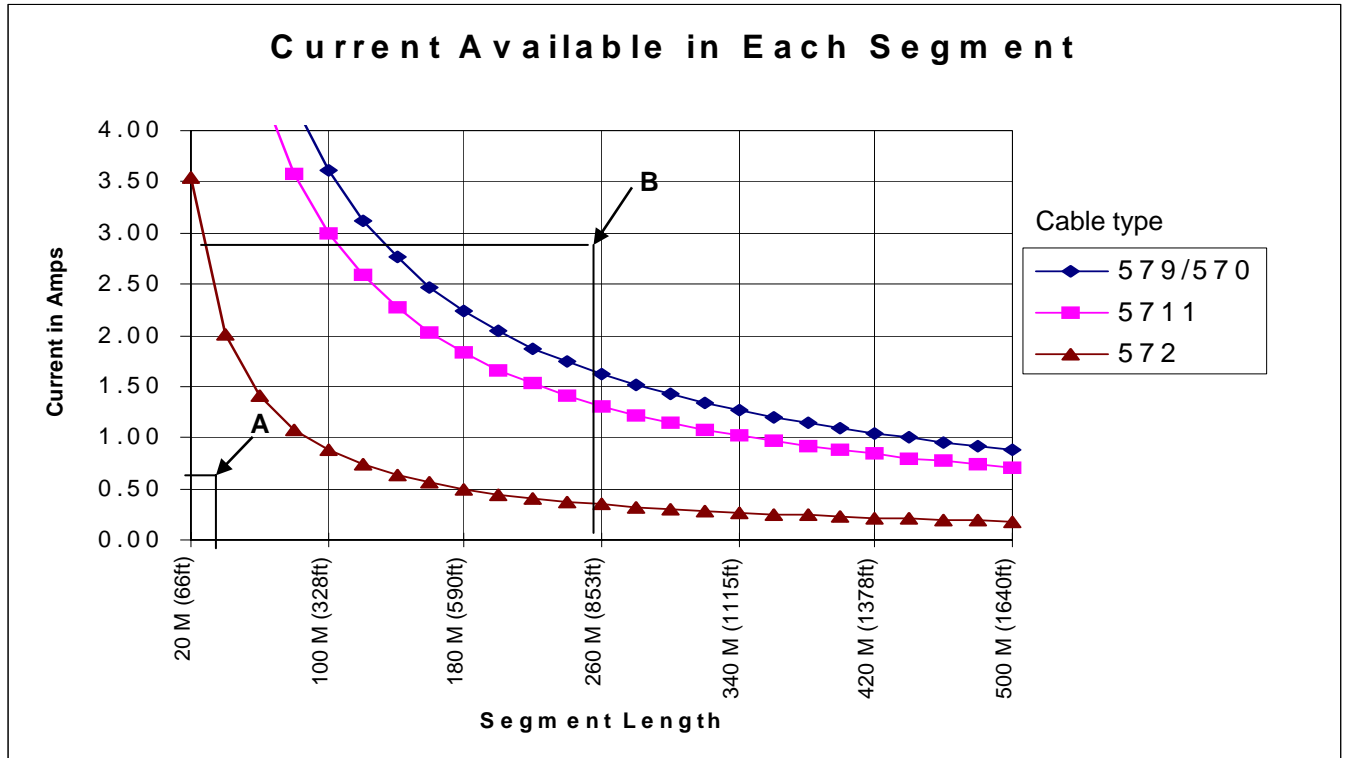

If each segment length and current value is under the curve the segment is OK.

For Segment A:

Total current = 580 mA

Total length of Segment A = 100 feet

Segment A is fine. Since it's below all three lines, any cable type can be used.

For Segment B:

Total current = 2.82 Amps

Total length = 800 feet

Segment B is above all three curves. This segment is outside the voltage drop limit for all cable types.

Step 6) Try a new layout and go back to *Step 4*. [Table II]

If both voltage drops are too large, more segments are needed.

If only one is too large, move the supply closer to the problem end.

In this case the voltage drop on segment A is great, but B is a problem. The system looks like we did not do a good job of putting the supply in the center. "Center" really means that both sides have similar voltage drops. There is another position (near node 11) where the power supply could be located. **Segment A = 500 feet, B = 400 feet**

Table II

Node	Distance to PS in Feet , Segment	Current in mA	Description
N 1	500, A	115	FDNP-S0808G-TT (with 4 world clamp proximity sensors)
N 2	490, A	75	FDNP-XSG16-TT (with 8 Part verification arrays each)
N 3	380, A	75	FDNP-XSG16-TT (with 8 Part verification arrays each)
N 4	470, A	75	FDNP-XSG16-TT (with 8 Part verification arrays each)
N 5	460, A	75	FDNP-XSG16-TT (with 8 Part verification arrays each)
N 6	450, A	75	FDNP-XSG16-TT (with 8 Part verification arrays each)
N 7	300, A	330	FDNL-S0800-T (with 8 photoelectric sensors each)
N 8	200, A	330	FDNL-S0800-T (with 8 photoelectric sensors each)
N 9	100, A	330	FDNL-S0800-T (with 8 photoelectric sensors each)
N 10	0, A	90	1747 SDN SLC 500 scanner card for PLC
N 11	10, B	330	FDNL-S0800-T (with 8 photoelectric sensors each)
N 12	100, B	420	FDNL-CSG88-T (with 8 pushbutton pendants each)
N 13	200, B	330	FDNL-S0800-T (with 8 photoelectric sensors each)
N 14	300, B	330	FDNL-S0800-T (with 8 photoelectric sensors each)
N 15	400, B	420	FDNL-CSG88-T (with 8 pushbutton pendants each)

For Segment A:

Total current is $115 + 75 \times 5 + 330 \times 3 + 90 = 1.57$ Amps

Total cable resistance is $3.25 \text{ Ohms}/1000 \text{ feet} \times 500 \text{ feet} + .005 \times 30 = 1.775$ Ohms

Total voltage drop is V- is $1.57 \text{ Amps} \times 1.775 \text{ Ohms} = 2.77$ Volts (worst case)

For Segment B:

Total current is $330 \times 3 + 420 \times 2 = 1.83$ Amps

Total cable resistance is $3.25 \text{ Ohms}/1000 \text{ feet} \times 400 \text{ feet} + .005 \times 10 = 1.35$ Ohms

Total voltage drop is $1.83 \times 1.35 \text{ Ohms} = 2.47$ Volts (worst case)

The new power supply location will work fine – both segments drop less than 3 V.

Methods to help reduce voltage drop:

Center power supply

The best way to minimize voltage drop is to put the power supply in the middle of the network rather than at one end. This will typically reduce your voltage drop by a factor of four.

Use low current nodes

Use a FDNP-XSG16-TT node for input up to 16 sensors. This node only consumes 75 mA from DeviceNet. All I/O is powered from the auxiliary power.

Use thick trunk cable

The lower the resistance, the lower the voltage drop.