

# sensoplex<sup>®</sup>

*sensoplex* is TURCK's own proprietary network originally introduced in 1987. *sensoplex* was designed for tough industrial environments and is highly noise resistant. It can interface to other device level networks, such as DeviceNet™, Modbus and PROFIBUS®-DP. An intrinsic safe version of *sensoplex* is available.

Bus Type	Master-to-slave
Bus Topology	Bus, straight feed-through
Transmission Speed	188 kBaud (fixed)
Transmission Medium	Coax Cable (supplies communication and power)
Transmission Signal	FSK (Frequency Shift Key) modulation; one data bit every 5.3 microseconds
Maximum Number of Nodes	32 to 64
Network Length	250 meters per branch
Address Setting	Via DIP Switch

**sensoplex® , Cable Specifications**

- Cable that Meets the Requirements of *sensoplex 2* Installations
- Cable is a 75 Ohm Impedance Coaxial Cable
- Coaxial Cable Allows both Power and Signal to be Transferred to the Field Devices

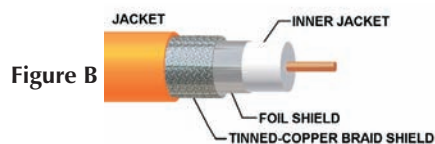
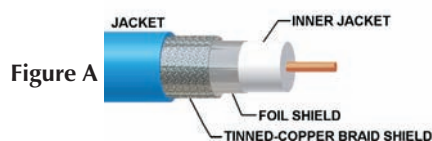

Type	Approvals	Inner Conductor		Outer Jacket	Shields	Bulk Cable Part Number / Weight/300 M	Figure
		Type	Material Insulation	Material Color Nominal O.D.	Type		
<b>Koax-75/B-Flex</b> 80°C 30 Volts	VDE 04721/0298	Flexible	Copper Alloy PE	TPE Blue 7 mm (.276 in)	Foil/Braid	RB82701-*M 33 lbs.	A
<b>Koax-75/B</b> 80°C 30 Volts	VDE 04721/0298	Solid	Alloy PE	TPE Blue 7 mm (.276 in)	Foil/Braid	RB82702-*M 33 lbs.	A
<b>Koax-75/OR-Flex</b> 80°C 30 Volts	VDE 04721/0298	Flexible	Copper Alloy PE	TPE Orange	Foil/Braid	RB82700-*M 33 lbs.	B
<b>Koax-75/OR</b> 80°C 30 Volts	VDE 04721/0298	Solid	Alloy PE	TPE Orange	Foil/Braid	RB50100-*M 33 lbs.	B

\* Indicates length in meters.

Standard cable lengths are 30, 75, 150, 225, and 300 meters.

## sensoplex<sup>®</sup>, Cable and Cordset Selection Matrix

		Straight		Right Angle	
		1	RS	2	WS
Bare			KOAX-RS-*M-XX		KOAX-WS-*M-XX
Straight	1	RS	KOAX-RS-*M-XX-RS	WS	KOAX-RS-*M-XX-WS
	2	WS			KOAX-WS-*M-XX-WS

\* Indicates length in meters.

Standard cable lengths are 1.0, 2.0, 4.0, 6.0, 10...15 Meters. Consult factory for other lengths.

For stainless steel coupling nuts change part number RS... to RSV, WS... to WSV.

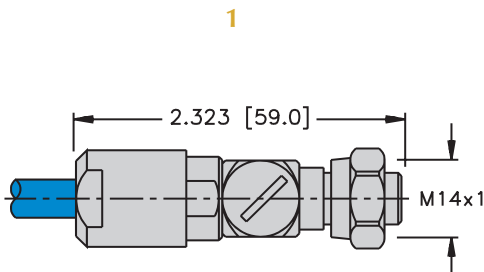
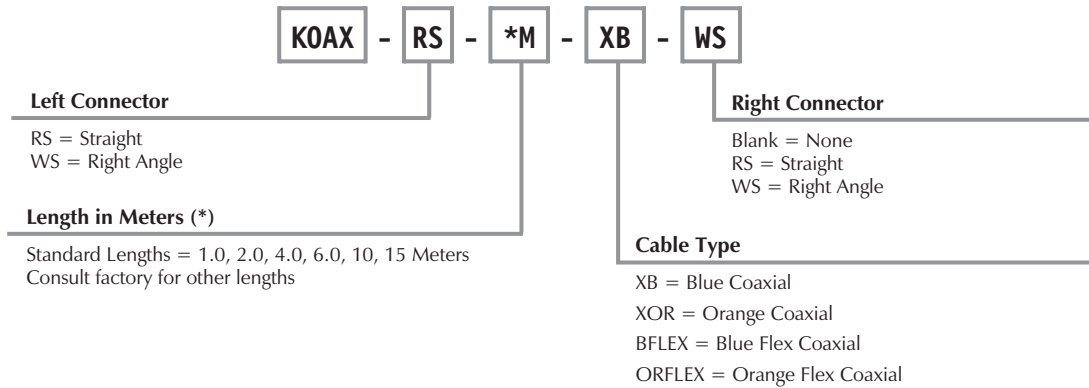

RS ..

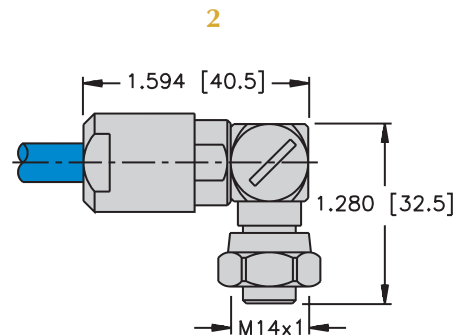

WS ..