

PROCESS WIRING



TURCK

Process Wiring Products

TURCK Process Wiring Solutions

This catalog contains products from **TURCK's** extensive line of industrial wiring products that are optimized for process applications. The receptacles, drop cords, junction boxes, home-run cables and accessories described within, comprise a process wiring system designed for the demanding conditions of process applications.

- Quick-disconnect design eliminates mis-wiring and speeds installation.
- Instrument receptacles, drop cords, junction boxes and home-run cordsets reduce multiple cable runs.
- Shielded-twisted pair construction serves analog and HART applications.
- Cables with premium PVC insulation provide superior chemical resistance and flexibility.
- Choice of stainless steel or nickel-plated brass hardware.
- Rated and approved for installation in process applications.
- Many products are FM approved for installations in hazardous locations.





2-Wire Analog or HART Control Circuits

M12 eurofast®	Page
Part Number Keys	K12
Drop Cordsets	K15
Receptacles with Cable	K20
Receptacles with Leads	K27
Junction Boxes	K33

7/8" minifast®	Page
Part Number Keys	K43
Drop Cordsets	K47
Receptacles with Cable	K55
Receptacles with Leads	K63
Explosionproof Receptacles	K73
"Y" Fitting Receptacles	K77
Junction Boxes	K79

M23 multifast®	Page
Home Run Cordsets	K85
Receptacles with Cable	K93
Receptacles with Leads	K95

Additional Analog or Discrete Control Circuits

M12 eurofast	Page
Part Number Keys	K98
Drop Cordsets	K101
Receptacles with Cable	K105
Receptacles with Leads	K109
Junction Boxes	K113

7/8", 1", & 1-1/8" minifast	Page
Part Number Keys	K117
Drop Cordsets	K121
Receptacles with Cable	K129
Receptacles with Leads	K144
Explosionproof Receptacles	K161
"Y" Fitting Receptacles	K169
Junction Boxes	K171

M23 multifast	Page
Home Run Cordsets	K173

NAMUR Circuits	K176
----------------	------

extremelife® Cordsets	K194
-----------------------	------

General Accessories	K206
---------------------	------

reelfast® Cable Selection Guide	K236
---------------------------------	------

Reference-Standards	K245
---------------------	------

Installation Instructions	K252
---------------------------	------

Code Requirements for Flexible Process Wiring Products Ordinary (Nonhazardous) Locations

Figure 1



Type ITC cable, or Instrumentation Tray Cable, provides a cost effective alternative for installation of low power instrumentation and control circuits. The National Electrical Code's (NEC) Article 727 permits the use of ITC- rated cables "in industrial establishments where the conditions of maintenance and supervision ensure that only qualified persons service the installation". It may be used in "instrumentation and control circuits operating at 150 volts or less and 5 amps or less." Permitted uses include installation in cable trays or basket trays (Figure 1), or as Exposed Run wiring in specified circumstances.

One of the permitted uses as of ITC cable is illustrated in Figure 2. NEC, Article 727.4(5) allows ITC cable without metallic sheath or armor between cable tray and equipment in lengths not to exceed 15 m (50 ft.), where the cable is supported and protected against physical damage using mechanical protection, such as struts, angles, or channels.

Figure 2

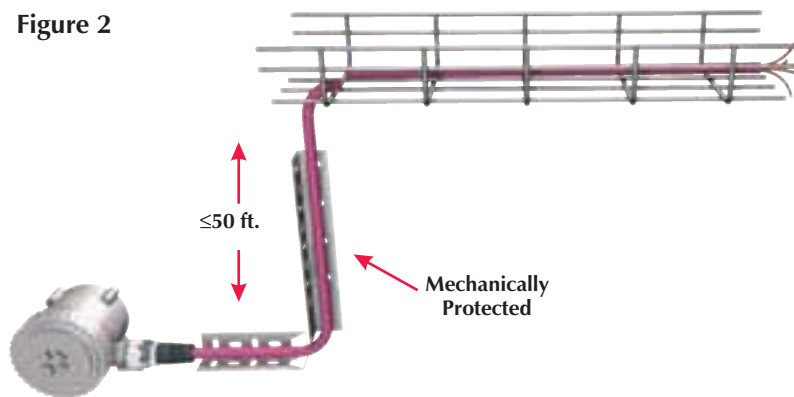
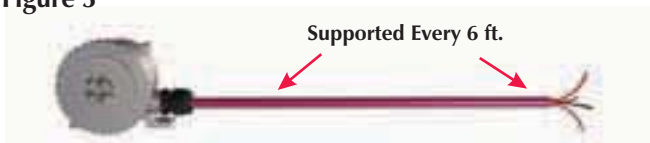

Figure 3



Another permitted use of ITC cable that increases flexibility is illustrated in Figure 3. NEC Article 727.4 (4) allows ITC cable to be used where enclosed in a smooth metallic sheath, continuous corrugated metallic sheath, or interlocking tape armor applied over the nonmetallic sheath in accordance with 727.6. The cable shall be supported and secured at intervals not exceeding 1.8 m (6 ft.)."

When using armored cable, there is no requirement for further mechanical protection or a length limitation. When using ITC cable that complies with the requirements of NEC 727.4(6) no further protection is required.



Code Requirements for Flexible Process Wiring Products Ordinary (Nonhazardous) Locations

NEC 727.4(6) allows the installation of ITC cable that complies with the crush and impact of Type MC cable between the cable tray and equipment in lengths not to exceed 15 m (50 ft.) without additional protection. Cable meeting this requirement is identified as "Exposed Run" or "ER" (Figure 1).

This concept enables convenient wiring methods, given that drops from a cable tray may be made without additional auxiliary trays or raceways. Additionally, ITC cable uses 300 volt insulation, resulting in smaller diameter, more flexible cable, with no requirement for special (e.g. Class 2) power supplies. When the ITC cable concept is combined with the **TURCK** process wiring system, the result is an extremely flexible and cost-effective system for process wiring. The basic building blocks of the system are device receptacles, junction boxes, and molded cordsets.

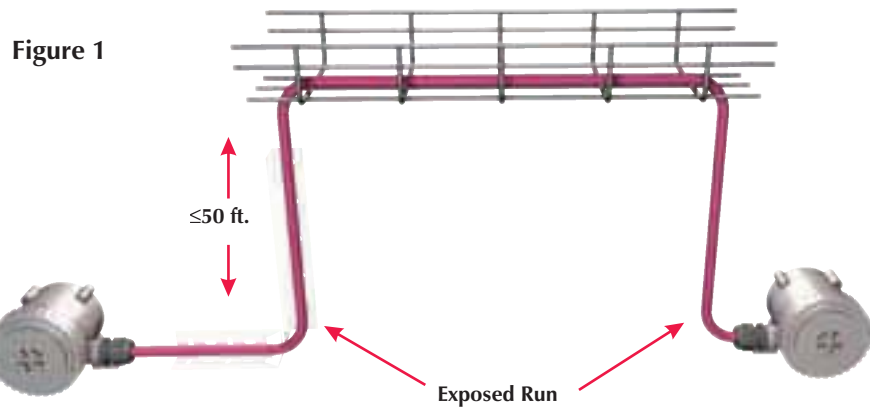
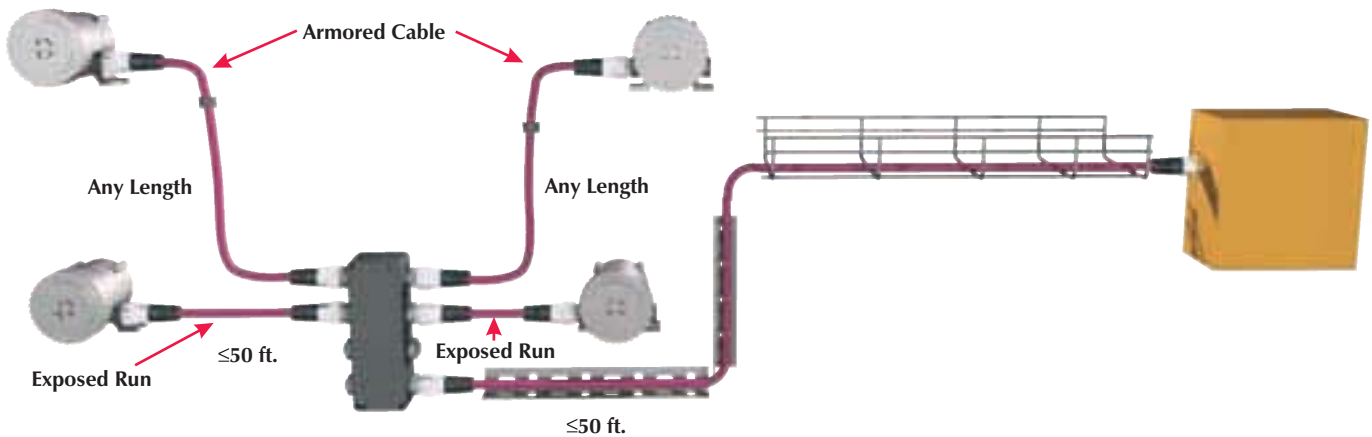

Figure 2



TURCK

Process Wiring Products

The **TURCK** process wiring system provides an integrated, code-compliant wiring method that adds the benefits of quick-disconnects to the ITC cable installation concepts.



Receptacles with 1/2-14NPT and 3/4-14NPT threads, as well as M20x1.5, easily extend the benefits of quick-disconnect wiring to most process instruments.

Junction boxes can significantly consolidate field wiring. They are available in metal or nylon housings with 4 or 8 ports and home-run quick-disconnects or integral home-run cables.



Molded quick-disconnect cordsets, using ITC cable, provide the ratings and performance characteristics required for process applications.



Hazardous Locations

Even more value can be derived from the **TURCK** process wiring system in hazardous locations. The system is now FM approved for use in Class I, Divisions 1 and 2 when installed per **TURCK** drawing QCF-00147 and CSA certified when installed per **TURCK** control drawing Ni-2.404. Contact **TURCK** for a copy of the approval documents or visit www.turck.com/fmcd.

Intrinsically Safe Circuits

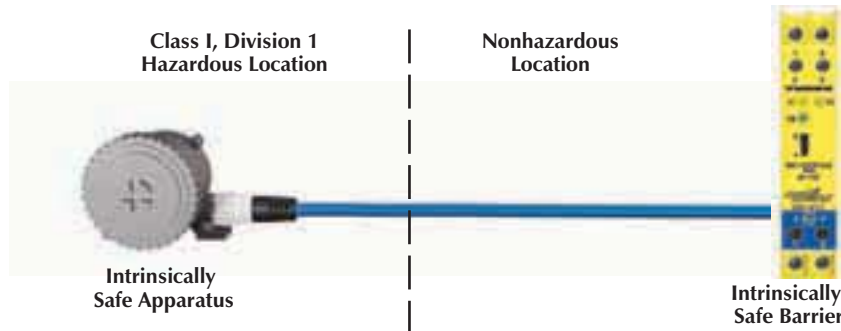

Intrinsically safe circuits may be wired using any of the wiring methods suitable for unclassified locations. The use of connectors is allowed as intrinsically safe circuits are safe against faults, including opening, shorting or grounding.

The same requirements for mechanical protection and length limitations apply as in nonhazardous locations.

Nonincendive Equipment*

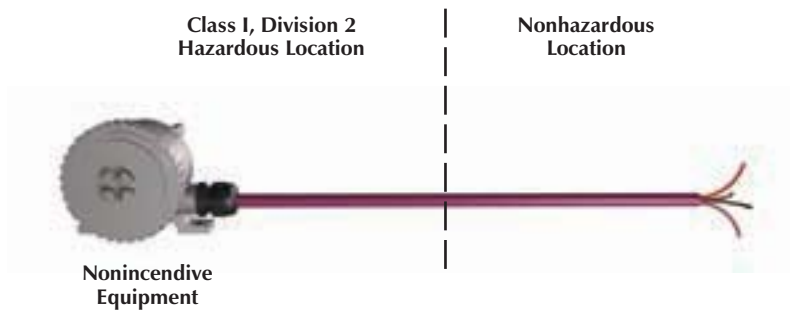

FM:

ITC cable is a recognized Division 2 wiring method. NEC in Article 501.10 (B)(1)(5) states "Type ITC cable as permitted in 727.4". This is further reinforced by Article 727.4 (3), which states that ITC cable is permitted "in hazardous locations as permitted in 501.10,...".

The same requirements for mechanical protection and length limitations apply as in nonhazardous locations.

CSA:

Canadian installations require the use of specific cable types for non-intrinsically safe circuits in Class I, Division 2 areas. **TURCK** offers CMX-HL cables for unprotected cable runs and CIC cable (Control and Instrumentation Cable) for cable runs in cable trays.

TURCK

Process Wiring Products

Quick-disconnects that do not require a tool to disengage are considered “normally arcing”. They are not allowed to be used in Division 2 for incandive circuits without additional protection.

lokfast™ guards enable the use of quick-disconnect technology in Class I, Division 2 hazardous locations.

lokfast guards render quick-disconnects not “normally arcing” by:

- Eliminating access to the coupling nut making disconnection impossible.
- Warning the user to disconnect power before removing.
- Requiring a tool for removal.



lokfast guards are available for 7/8-16UN **minifast®** and M12 **eurofast®** molded and field-wireable connectors.

Optional M23 **multifast®** home-run connectors with set screw locks also render a connection not “normally arcing”.



lokfast guards (or integrally locked **multifast** connectors) on all quick disconnects in Division 2 (Figure 1).

The molded construction of the home-run connector and the gas/vapor tight continuous sheath meet the NEC Article 501-15(E)(2) requirements for cable seals in Division 2.

The same requirements for mechanical protection and length limitations apply as in to nonhazardous locations.

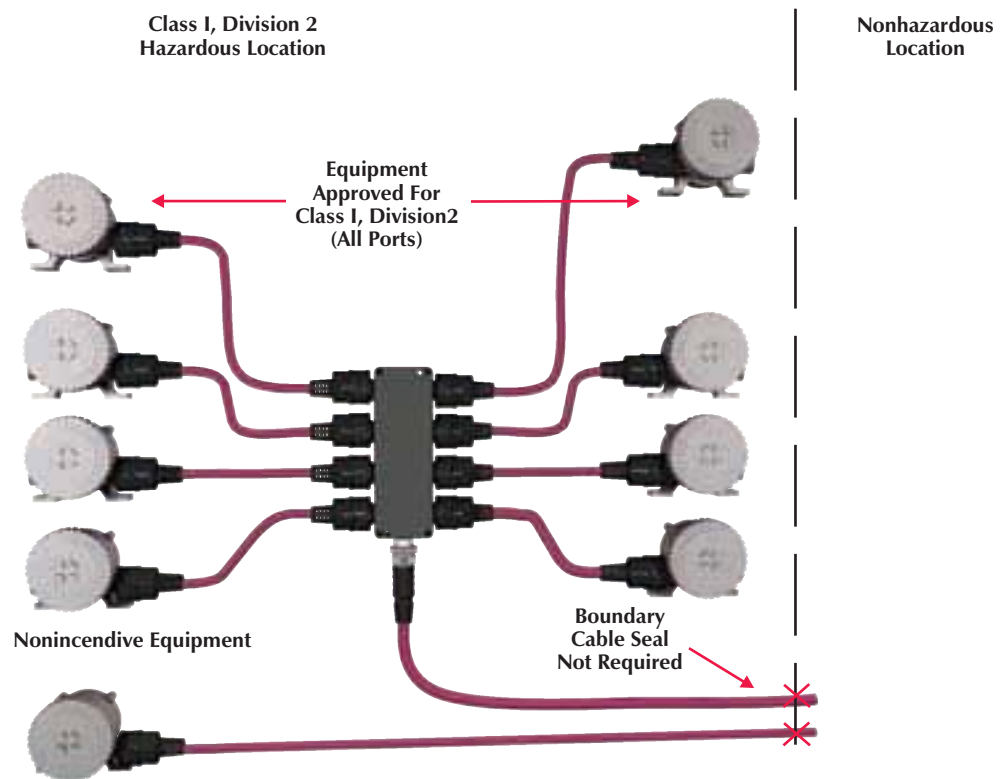

Figure 1



Intrinsic Safety Summary

Intrinsically safe circuits do not require additional protection for quick-disconnects.

Junction boxes must have FM-approved spacings and entity parameters for intrinsically safe circuits.

Boundary seals are not required for this location, as the molded home-run connector and the gas/vapor tight continuous cable sheath meet the NEC Article 501-15©) requirements for cable seals in Class I, Divisions 1 and 2.

Requirements for mechanical protection and length limitations are equivalent to nonhazardous locations.

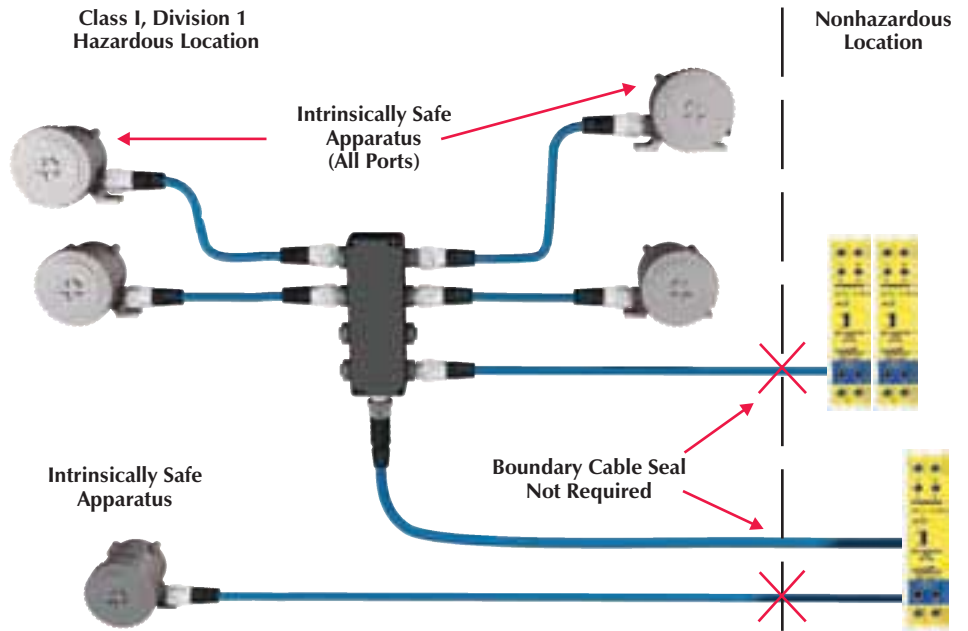

Explosionproof Equipment

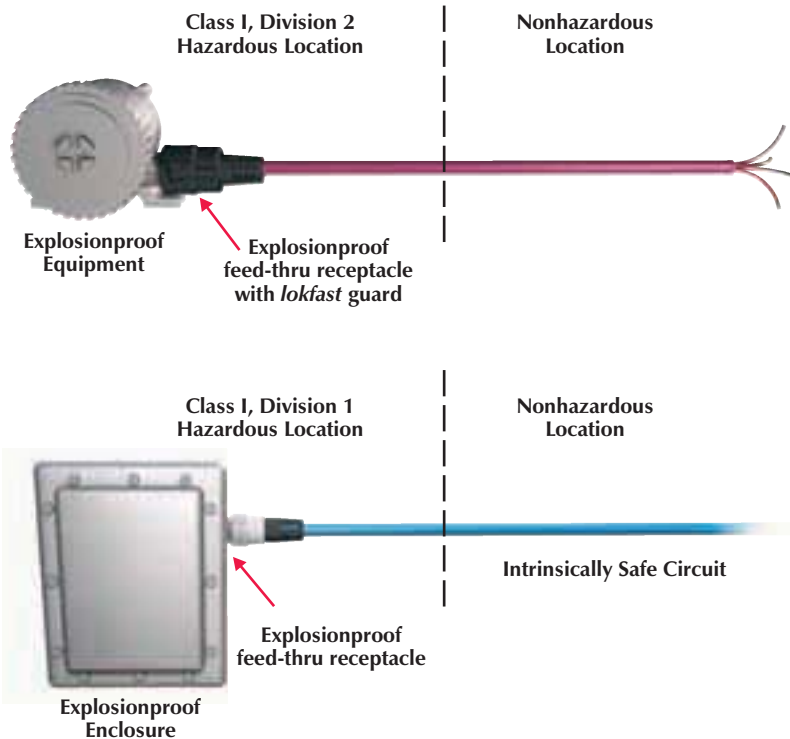

ITC cable, a recognized Division 2 wiring method, may be used to connect Explosionproof equipment installed in Division 2 when used with an explosionproof feed-through receptacle. The extremely robust receptacle maintains the equipment's explosion containment protection scheme. The external wiring, however, is in Division 2, and can therefore be installed using Division 2 wiring methods.

Explosionproof feed-thru receptacles may also be used to feed intrinsically safe circuits into or out of explosionproof enclosures in Class I, Division 1 hazardous locations.