





## E-Stop &amp; Guard Monitoring Modules

Model	Functional Stop Category	Supply Voltage	Inputs	Safety Outputs	Output Rating	Aux. Outputs	Output Response Time	Delay	Data Sheet
GM-FA-10J	0	24V ac/dc	1 NC (single) or 1 NC & 1 NO (dual)	<b>2 NO</b>	6 amps	—	35 ms	—	60998
ES-FA-9AA	0	24V ac/dc	1 NC (single) or 2 NC (dual)	<b>3 NO</b>	6 amps	—	25 ms	—	60606
ES-FA-11AA				<b>2 NO</b>		1 NC			
ES-UA-5A	0	115V ac & 12-24V dc	1 NC (single) or 2 NC (dual)	<b>4 NO</b>	6 amps	1 NC & 2 PNP	25 ms	—	122365
ES-VA-5A		230V ac & 12-24V dc							
ES-TN-1H5	0 & 1	24V dc	1 NC (single) or 2 NC (dual)	<b>2 NO &amp; 2 NO w/delay</b>	4 amps	1 NC (delayed) & 1 NC (immediate)	50 ms	0 - 20 sec.	61061
ES-TN-1H6								0 - 200 sec.	
ES-TN-1H1								0.25 sec.	
ES-TN-1H2								0.5 sec.	
ES-TN-1H3								1.0 sec.	
ES-TN-1H4								2.0 sec.	
ES-TN-1H7								4.0 sec.	
ES-TN-1H8								6.0 sec.	
ES-TN-1H9								8.0 sec.	
ES-TN-1H10								10.0 sec.	
ES-TN-1H11								15.0 sec.	
ES-TN-1H12								20.0 sec.	
ES-TN-14H5	0 & 1	24V dc	1 NC (single) or 2 NC (dual)	<b>4 NO &amp; 4 NO w/delay</b>	4 amps	1 NC (delayed) & 1 NC (immediate)	50 ms	0 - 20 sec.	68436
ES-TN-14H6								0 - 200 sec.	
ES-FA-6G	0	24V ac/dc	1 NC (single)	<b>3 NO</b>	6 amps	1 NC	35 ms	—	55581

NC = Normally Closed Relay, NO = Normally Open Relay

## GM-FA-10J Guard Monitoring Module Specifications

Supply Voltage and Current	24V ac/dc $\pm$ 20% <b>Power consumption:</b> approx. 3 VA / 3 W												
Supply Protection Circuitry	Protected against transient voltages and reverse polarity												
Output Configuration	<p>Each normally open output channel is a series connection of contacts from two forced-guided (mechanically linked) relays, K1-K2.</p> <p><b>Contacts:</b> AgNi, 5 <math>\mu</math>m gold-plated</p> <p><b>Low Current Rating:</b></p> <p><b>Caution: The 5 <math>\mu</math>m gold-plated contacts allow the switching of low current/low voltage.</b></p> <p>To preserve the gold plating on the contacts, do not exceed the following max. values at any time:</p> <table> <tr> <td><b>Min. voltage:</b> 1V ac/dc</td> <td><b>Max. voltage:</b> 60V</td> </tr> <tr> <td><b>Min. current:</b> 5 mA ac/dc</td> <td><b>Max. current:</b> 300 mA</td> </tr> <tr> <td><b>Min. power:</b> 5 mW (5 mVA)</td> <td><b>Max. power:</b> 7 W (7 VA)</td> </tr> </table> <p><b>High Current Rating:</b></p> <p>If higher loads must be switched through one or more of the contacts, the minimum and maximum values of the contact(s) changes to:</p> <table> <tr> <td><b>Min. voltage:</b> 15V ac/dc</td> <td><b>Max. voltage:</b> 250V ac/dc</td> </tr> <tr> <td><b>Min. current:</b> 30 mA ac/dc</td> <td><b>Max. current:</b> 6 A</td> </tr> <tr> <td><b>Min. power:</b> 5 W (5 VA)</td> <td><b>Max. power:</b> 200 W (1,500 VA)</td> </tr> </table> <p><b>Mechanical life:</b> 50,000,000 operations <b>Electrical life:</b> 150,000 cycles typical, @ 200 W (1,500 VA) switched power, resistive load</p> <p><b>Note: Transient suppression is recommended when switching inductive loads. Install suppressors across load. Never install suppressors across output contacts.</b></p>	<b>Min. voltage:</b> 1V ac/dc	<b>Max. voltage:</b> 60V	<b>Min. current:</b> 5 mA ac/dc	<b>Max. current:</b> 300 mA	<b>Min. power:</b> 5 mW (5 mVA)	<b>Max. power:</b> 7 W (7 VA)	<b>Min. voltage:</b> 15V ac/dc	<b>Max. voltage:</b> 250V ac/dc	<b>Min. current:</b> 30 mA ac/dc	<b>Max. current:</b> 6 A	<b>Min. power:</b> 5 W (5 VA)	<b>Max. power:</b> 200 W (1,500 VA)
<b>Min. voltage:</b> 1V ac/dc	<b>Max. voltage:</b> 60V												
<b>Min. current:</b> 5 mA ac/dc	<b>Max. current:</b> 300 mA												
<b>Min. power:</b> 5 mW (5 mVA)	<b>Max. power:</b> 7 W (7 VA)												
<b>Min. voltage:</b> 15V ac/dc	<b>Max. voltage:</b> 250V ac/dc												
<b>Min. current:</b> 30 mA ac/dc	<b>Max. current:</b> 6 A												
<b>Min. power:</b> 5 W (5 VA)	<b>Max. power:</b> 200 W (1,500 VA)												
Output Response Time	35 milliseconds												
Input Requirements	<p><b>Input switch</b> must have a normally closed contact and a normally open contact capable of switching 5 to 50 mA @ 15 to 30 V dc.</p> <p><b>Reset switch</b> must have one normally open contact capable of switching 5 to 50 mA @ 15 to 30V dc. Max. external resistance between terminals S11/S12, S11/S13, S21/S22 and S21/S23: 270 <math>\Omega</math> each.</p>												
Simultaneity Monitoring	<p><b>2-Channel operation:</b> 3 seconds</p> <p><b>1-Channel operation:</b> infinite</p>												
Status Indicators	<table> <tr> <td><b>4 green LEDs:</b></td> <td><b>1 red LED:</b></td> </tr> <tr> <td>Power: power is supplied to Safety Module</td> <td>Fault</td> </tr> <tr> <td>Channel 1: inputs satisfied (guard closed)</td> <td></td> </tr> <tr> <td>Channel 2: inputs satisfied (guard closed)</td> <td></td> </tr> <tr> <td>Output: K1 and K2 energized, safety outputs closed</td> <td></td> </tr> </table>	<b>4 green LEDs:</b>	<b>1 red LED:</b>	Power: power is supplied to Safety Module	Fault	Channel 1: inputs satisfied (guard closed)		Channel 2: inputs satisfied (guard closed)		Output: K1 and K2 energized, safety outputs closed			
<b>4 green LEDs:</b>	<b>1 red LED:</b>												
Power: power is supplied to Safety Module	Fault												
Channel 1: inputs satisfied (guard closed)													
Channel 2: inputs satisfied (guard closed)													
Output: K1 and K2 energized, safety outputs closed													
Construction	Polycarbonate housing												
Environmental Rating	Rated NEMA 1; IEC IP40, Terminals IP20												
Mounting	Mounts to standard 35 mm DIN rail track. Safety Module must be installed inside an enclosure rated NEMA 3 (IEC IP54), or better.												
Vibration Resistance	10 to 55 Hz @ 0.35 mm displacement per IEC 68-2-6												
Operating Conditions	<b>Temperature:</b> 0° to +50° C <b>Relative humidity:</b> 90% @ +50° C (non-condensing)												
Safety Category	4 per ISO 13849-1 (EN954-1) (depending on application)												
Certifications	For a list of certifications see page 237.												
Wiring Diagrams	<p><b>1-Channel Coded Magnet Switches:</b> WD043 (p. 271)</p> <p><b>2-Channel Positive Opening Switches:</b> WD044 (p. 271)</p> <p><b>1-Channel (Multiple Guards):</b> WD045 (p. 272)</p> <p><b>2-Channel (Multiple Guards):</b> WD046 (p. 272)</p> <p><b>Guarded Machine:</b> WD047 (p. 274)</p>												

## ES-FA-..AA Safety Module Specifications

<b>Supply Voltage and Current</b>	24V ac/dc, +/- 10%; 50/60Hz <b>Power consumption:</b> approx. 2 W/2 VA												
<b>Supply Protection Circuitry</b>	Protected against transient voltages and reverse polarity												
<b>Output Configuration</b>	<p><b>ES-FA-9AA:</b> 3 normally open output channels <b>ES-FA-11AA:</b> 2 normally open output channels and 1 normally closed auxiliary output channel.</p> <p>Each normally open output channel is a series connection of contacts from two forced-guided (positive-guided) relays, K1-K2. The normally closed contact 31-32 is a parallel connection of contacts from K1-K2.</p> <p><b>Contacts:</b> AgNi, 5 µm gold-plated <b>Low Current Rating:</b> <b>Caution: The 5 µm gold-plated contacts allow the switching of low current/low voltage.</b> To preserve the gold plating on the contacts, the following max. values should not be exceeded at any time:</p> <table> <tr> <td><b>Min. voltage:</b> 1V ac/dc</td> <td><b>Max. voltage:</b> 60V</td> </tr> <tr> <td><b>Min. current:</b> 5 mA ac/dc</td> <td><b>Max. current:</b> 300 mA</td> </tr> <tr> <td><b>Min. power:</b> 5 mW (5 mVA)</td> <td><b>Max. power:</b> 7 W (7 VA)</td> </tr> </table> <p><b>High Current Rating:</b> If higher loads must be switched through one or more of the contacts, the minimum and maximum values of the contact(s) changes to:</p> <table> <tr> <td><b>Min. voltage:</b> 15V ac/dc</td> <td><b>Max. voltage:</b> 250V ac/dc</td> </tr> <tr> <td><b>Min. current:</b> 30 mA ac/dc</td> <td><b>Max. current:</b> 6 A (ES-FA-9AA) and 7A (ES-FA-11AA)</td> </tr> <tr> <td><b>Min. power:</b> 5 W (5 VA)</td> <td><b>Max. power:</b> 200 W (1,500 VA)</td> </tr> </table> <p><b>Mechanical life:</b> 50,000,000 operations <b>Electrical life: ES-FA-9AA:</b> 150,000 operations (typical, @ 200 W (1,500 VA) switched power, resistive load) <b>ES-FA-11AA:</b> 130,000 operations (typical, @ 200 W (1,750 VA) switched power, resistive load)</p> <p><b>Note: Transient suppression is recommended when switching inductive loads. Install suppressors across load. Never install suppressors across output contacts.</b></p>	<b>Min. voltage:</b> 1V ac/dc	<b>Max. voltage:</b> 60V	<b>Min. current:</b> 5 mA ac/dc	<b>Max. current:</b> 300 mA	<b>Min. power:</b> 5 mW (5 mVA)	<b>Max. power:</b> 7 W (7 VA)	<b>Min. voltage:</b> 15V ac/dc	<b>Max. voltage:</b> 250V ac/dc	<b>Min. current:</b> 30 mA ac/dc	<b>Max. current:</b> 6 A (ES-FA-9AA) and 7A (ES-FA-11AA)	<b>Min. power:</b> 5 W (5 VA)	<b>Max. power:</b> 200 W (1,500 VA)
<b>Min. voltage:</b> 1V ac/dc	<b>Max. voltage:</b> 60V												
<b>Min. current:</b> 5 mA ac/dc	<b>Max. current:</b> 300 mA												
<b>Min. power:</b> 5 mW (5 mVA)	<b>Max. power:</b> 7 W (7 VA)												
<b>Min. voltage:</b> 15V ac/dc	<b>Max. voltage:</b> 250V ac/dc												
<b>Min. current:</b> 30 mA ac/dc	<b>Max. current:</b> 6 A (ES-FA-9AA) and 7A (ES-FA-11AA)												
<b>Min. power:</b> 5 W (5 VA)	<b>Max. power:</b> 200 W (1,500 VA)												
<b>Output Response Time</b>	25 milliseconds typical												
<b>Input Requirements</b>	<b>Input switch</b> must have one or two normally closed contacts capable of switching 40 to 100 mA @ 13 to 27V ac/dc. <b>Reset switch</b> must have one normally open contact capable of switching 20 to 30 mA @ 13 to 27V ac/dc.												
<b>Minimum OFF-State Recovery Time</b>	250 milliseconds												
<b>Status Indicators</b>	<b>3 green LED indicators:</b> Power ON K1 energized K2 energized												
<b>Construction</b>	Polycarbonate housing												
<b>Environmental Rating</b>	Rated NEMA 1; IEC IP40, Terminals IP20												
<b>Mounting</b>	Mounts to standard 35 mm DIN rail track. Safety Module must be installed inside an enclosure rated NEMA 3 (IEC IP54), or better.												
<b>Vibration Resistance</b>	10 to 55Hz @ 0.35 mm displacement per IEC 68-2-6												
<b>Operating Conditions</b>	<b>Temperature:</b> 0° to +50° C <b>Relative humidity:</b> 90% @ +50° C (non-condensing)												
<b>Certifications</b>	For a list of certifications see page 237.												
<b>Wiring Diagrams</b>	<b>1-Channel:</b> WD048 (p. 275) <b>2-Channel:</b> WD049 (p. 276)												

## ES-..A-5A Safety Module Specifications

Supply Voltage and Current	<b>ES-UA-5A:</b> 115V ac (A1-A2), 12-24V dc, $\pm 15\%$ , 10% max. ripple (B1-B2) <b>ES-VA-5A:</b> 230V ac (A1-A2), 12-24V dc, $\pm 15\%$ , 10% max. ripple (B1-B2) <b>Power consumption:</b> approx. 7 VA/4 W												
Supply Protection Circuitry	Protected against transient voltages and reverse polarity												
Output Configuration	<p><b>Outputs (K1 &amp; K2):</b> four redundant (total of eight) safety relay (forced-guided) contacts – AgNi, 5 <math>\mu</math>m gold-plated, plus 1 normally closed auxiliary monitor output - AgNi, 5 <math>\mu</math>m gold-plated.</p> <p><b>Low Current Rating:</b>  <b>Caution: The 5 <math>\mu</math>m gold-plated contacts allow the switching of low current/low voltage.</b>  To preserve the gold plating on the contacts, the following max. values should not be exceeded at any time:</p> <table> <tr> <td><b>Min. voltage:</b> 1V ac/dc</td> <td><b>Max. voltage:</b> 60V</td> </tr> <tr> <td><b>Min. current:</b> 5 mA ac/dc</td> <td><b>Max. current:</b> 300 mA</td> </tr> <tr> <td><b>Min. power:</b> 5 mW (5 mVA)</td> <td><b>Max. power:</b> 7 W (7 VA)</td> </tr> </table> <p><b>High Current Rating:</b>  If higher loads must be switched through one or more of the contacts, the minimum and maximum values of the contact(s) changes to:</p> <table> <tr> <td><b>Min. voltage:</b> 15V ac/dc</td> <td><b>Max. voltage:</b> 250V ac/dc</td> </tr> <tr> <td><b>Min. current:</b> 30 mA ac/dc</td> <td><b>Max. current:</b> 6 A</td> </tr> <tr> <td><b>Min. power:</b> 5 W (5 VA)</td> <td><b>Max. power:</b> 200 W (1,500 VA)</td> </tr> </table> <p><b>Mechanical life:</b> 50,000,000 operations  <b>Electrical life:</b> 150,000 operations (typical, @ 1,500 VA switched power, resistive load)  150,000 operations (typical, @ 200 W switched power, resistive load)</p> <p><b>Note: Transient suppression is recommended when switching inductive loads. Install suppressors across load. Never install suppressors across output contacts.</b></p> <p><b>Solid-State Monitor Outputs:</b></p> <ul style="list-style-type: none"> <li>- Two non-safety solid-state dc outputs</li> <li>- Output at Y32 monitors state of outputs – conducts (output high) when both K1 and K2 are energized</li> <li>- Output at Y35 conducts (output high) when internal power supply is OK</li> <li>- Output circuits require application of +12-24V dc <math>\pm 15\%</math> at terminal Y31; dc common at Y30</li> <li>- Maximum switching current: 100 mA at 12-24V dc</li> <li>- Both outputs are protected against short circuits</li> </ul>	<b>Min. voltage:</b> 1V ac/dc	<b>Max. voltage:</b> 60V	<b>Min. current:</b> 5 mA ac/dc	<b>Max. current:</b> 300 mA	<b>Min. power:</b> 5 mW (5 mVA)	<b>Max. power:</b> 7 W (7 VA)	<b>Min. voltage:</b> 15V ac/dc	<b>Max. voltage:</b> 250V ac/dc	<b>Min. current:</b> 30 mA ac/dc	<b>Max. current:</b> 6 A	<b>Min. power:</b> 5 W (5 VA)	<b>Max. power:</b> 200 W (1,500 VA)
<b>Min. voltage:</b> 1V ac/dc	<b>Max. voltage:</b> 60V												
<b>Min. current:</b> 5 mA ac/dc	<b>Max. current:</b> 300 mA												
<b>Min. power:</b> 5 mW (5 mVA)	<b>Max. power:</b> 7 W (7 VA)												
<b>Min. voltage:</b> 15V ac/dc	<b>Max. voltage:</b> 250V ac/dc												
<b>Min. current:</b> 30 mA ac/dc	<b>Max. current:</b> 6 A												
<b>Min. power:</b> 5 W (5 VA)	<b>Max. power:</b> 200 W (1,500 VA)												
Output Response Time	25 milliseconds typical												
Input Requirements	<p><b>Input switch</b> must have normally closed contacts each capable of switching 20 to 50 mA @ 12 to 30V dc; and must be open <math>\geq 10</math> milliseconds for a valid stop command.</p> <p><b>Reset switch</b> must have one normally open contact capable of switching 20 to 50 mA @ 12 to 30V ac/dc.</p>												
ON-Time Delay	80 milliseconds; time from the E-stop contacts to close (Auto Reset) or the reset button to open (Manual Reset) and the safety outputs to close.												
Status Indicators	<table> <tr> <td> <b>3 green LED indicators:</b>  Power ON  K1 energized  K2 energized </td> <td> <b>1 Red LED indicator:</b>  Fault (internal power supply, ground fault, short across the input channels or other internal failures) </td> </tr> </table>	<b>3 green LED indicators:</b> Power ON K1 energized K2 energized	<b>1 Red LED indicator:</b> Fault (internal power supply, ground fault, short across the input channels or other internal failures)										
<b>3 green LED indicators:</b> Power ON K1 energized K2 energized	<b>1 Red LED indicator:</b> Fault (internal power supply, ground fault, short across the input channels or other internal failures)												
Construction	Polycarbonate housing												
Environmental Rating	Rated NEMA 1; IEC IP20												
Mounting	Mounts to standard 35 mm DIN rail track. Safety Module must be installed inside an enclosure rated NEMA 3 (IEC IP54), or better.												
Vibration Resistance	10 to 55Hz @ 0.35 mm displacement per IEC 68-2-6												
Operating Conditions	<b>Temperature:</b> 0° to +50° C <b>Relative humidity:</b> 90% @ +50° C (non-condensing)												
Certifications	For a list of certifications see page 237.												
Wiring Diagrams	<b>1-Channel:</b> WD050 (p. 277) <b>2-Channel:</b> WD051 (p. 278)												

## ES-TN-1H.. Safety Module Specifications

<b>Supply Voltage and Current</b>	24V dc, ±20% <b>Power consumption:</b> approx. 5 W									
<b>Supply Protection Circuitry</b>	Protected against transient voltages and reverse polarity									
<b>Output Configuration</b>	<p><b>Outputs K1 &amp; K2:</b> Two redundant (total of four) safety relay (forced-guided) contacts – AgNi, gold flashed one auxiliary normally closed contact – AgNi, gold flashed</p> <p><b>Outputs K3 &amp; K4:</b> Two redundant (total of four) delayed relay (forced-guided) contacts – AgNi, gold flashed one auxiliary normally closed contact – AgNi, gold flashed</p> <p><b>Contact ratings (all normally open and normally closed output contacts):</b></p> <p><b>Max. voltage:</b> 250V ac or 250V dc  <b>Max. current:</b> 4 A ac or dc  <b>Min. current:</b> 30 mA @ 24V dc  <b>Max. power:</b> 1000 VA, 100 W  <b>Mechanical life:</b> 50,000,000 operations  <b>Electrical life:</b> 100,000 at full resistive load</p> <p><b>NOTE:</b> Transient suppression is recommended when switching inductive loads. Install suppressors across load. Never install suppressors across output contacts.</p>									
<b>Output Response Time</b>	<p><b>K1 &amp; K2:</b> 50 milliseconds typical  <b>K3 &amp; K4 (ES-TN-1H1):</b> 0.25 second  <b>K3 &amp; K4 (ES-TN-1H2):</b> 0.5 second  <b>K3 &amp; K4 (ES-TN-1H3):</b> 1.0 second  <b>K3 &amp; K4 (ES-TN-1H4):</b> 2.0 seconds  <b>K3 &amp; K4 (ES-TN-1H5):</b> 0, 0.5, 1, 2, 4, 6, 8, 10, 15, 20 seconds  <b>K3 &amp; K4 (ES-TN-1H6):</b> 0, 5, 10, 20, 30, 50, 70, 100, 150, 200 seconds  <b>K3 &amp; K4 (ES-TN-1H7):</b> 4.0 seconds  <b>K3 &amp; K4 (ES-TN-1H8):</b> 6.0 seconds  <b>K3 &amp; K4 (ES-TN-1H9):</b> 8.0 seconds  <b>K3 &amp; K4 (ES-TN-1H10):</b> 10.0 seconds  <b>K3 &amp; K4 (ES-TN-1H11):</b> 15.0 seconds  <b>K3 &amp; K4 (ES-TN-1H12):</b> 20.0 seconds</p> <p><b>Delayed Output Timing Tolerance:</b> Set time ±100 milliseconds or ±2%, whichever is greater</p>									
<b>Input Requirements</b>	<p><b>Input switch</b> must have a normally closed contact capable of switching 20 mA @ 24V dc.  <b>Reset switch</b> must have one normally open contact capable of switching 20 mA @ 24V dc.  <b>NOTE:</b> Inputs must be voltage-free, dry contacts.</p>									
<b>ON-Time Delay</b>	≥ 100 milliseconds; time from the E-stop contacts to close (Auto Reset) or the Reset button to open (Manual Reset) and the safety outputs to close.									
<b>Status Indicators</b>	<p><b>6 green LED indicators:</b></p> <table> <tr> <td>Power</td> <td>Monitor</td> <td><b>1 red LED indicator:</b></td> </tr> <tr> <td>E-Stop</td> <td>Out (K1 &amp; K2 ON/OFF)</td> <td>Fault</td> </tr> <tr> <td>Reset</td> <td>Timed-Out (K3 &amp; K4 ON/OFF)</td> <td></td> </tr> </table>	Power	Monitor	<b>1 red LED indicator:</b>	E-Stop	Out (K1 & K2 ON/OFF)	Fault	Reset	Timed-Out (K3 & K4 ON/OFF)	
Power	Monitor	<b>1 red LED indicator:</b>								
E-Stop	Out (K1 & K2 ON/OFF)	Fault								
Reset	Timed-Out (K3 & K4 ON/OFF)									
<b>Construction</b>	Polycarbonate housing									
<b>Environmental Rating</b>	Rated NEMA 1; IEC IP40, Terminals IP20, max. terminal torque 0.8 Nm									
<b>Mounting</b>	Mounts to standard 35 mm DIN rail track. Safety Module must be installed inside an enclosure rated NEMA 3 (IEC IP54), or better.									
<b>Vibration Resistance</b>	10 to 55Hz @ 0.35 mm displacement per IEC 68-2-6									
<b>Operating Conditions</b>	<b>Temperature:</b> 0° to +50° C <b>Relative humidity:</b> 90% @ +50° C (non-condensing)									
<b>Certifications</b>	For a list of certifications see page 237.									
<b>Wiring Diagrams</b>	<b>2-Channel:</b> WD052 (p. 279)									

## 3RG7847-4BB

SIMATIC PS 400

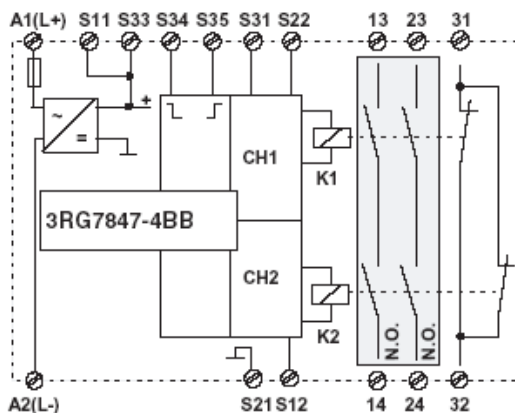
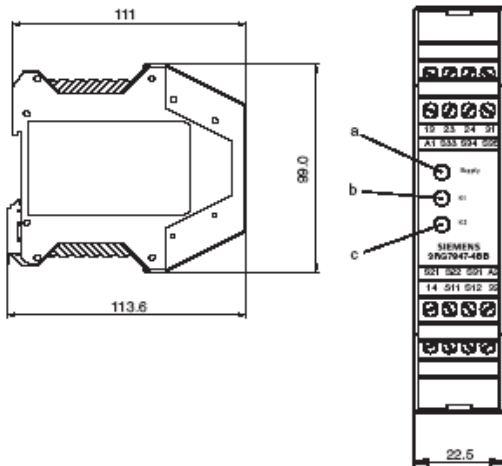

## SIEMENS

Siemens Aktiengesellschaft  
Automation and Drives  
Factory Automation Sensors  
Postfach 4848  
D-90497 NURENBERG, GERMANY  
<http://www.siemens.com/simatic-sensors>

### 3RG7847-4BB Standard Evaluation Unit for Light Curtains in accordance with IEC-, EN 60204-1 Stop Category 0, depending on wiring up to cat. 4 (EN 954-1)

#### Connecting and Operating Instructions About these Connecting and Operating Instructions

These operating instructions contain information regarding proper equipment use. It is included in the scope of delivery. Safety precautions and warnings are designated by the symbol . Siemens AG is not liable for damage resulting from improper use of its equipment. Familiarity with these instructions constitutes part of the knowledge required for proper use.

#### 1. System Overview and Range of Applications

- a = Supply voltage on (LED green)
- b = Relay K1 activated
- c = Relay K2 activated

- 1- or 2-channel Emergency-Stop wiring
- Cross circuit recognition
- Monitoring of external contactors (EDM) in the push-button circuit
- Monitored start button
- Automatic or manual start
- 2 release circuits, 1 normal closed contact as signal circuit
- LED displays for Power, K1 and K2
- Operating voltage 24 V AC/DC
- Housing width 22.5 mm

#### Range of Applications

- Single-channel Emergency-Stop wiring, acc. EN 954-1 to Cat. 2
- Two-channel Emergency-Stop switching with cross circuit recognition (to Cat. 4, EN 954-1)
- Sequential circuitry for safety light barriers, Type 4, with relay or semiconductor outputs

#### 2. Safety Precautions

- Improper or inappropriate use can result in danger to the life and limbs of the machine operator or in damage to property.
- The relevant regulations are valid for the use of 3RG7847-4BB Emergency-Stop relays. The category of Emergency-Stop function must be determined under consideration of the risk evaluation of the machinery. The responsible local authorities are available to answer questions related to safety issues.
- 3RG7847-4BBF is suited only for uncontrolled shut-down (IEC 60204-1 Stop Category 0).
- The mechanical and electrical installation is to be performed by trained specialists.
- The voltage supply to the system must be switched off before and during installation.
- Contact mechanisms with positive guided contacts must be implemented for the contact multiplication of the release circuits.

#### 3. Function Single-Channel Emergency-Stop Wiring with Manual Start (Connection diagram Fig. 3)

After the supply voltage is applied to A1 and A2, and if the Emergency-Stop button is not pressed, the relays K1 and K2 pick up and lock when the start button is pressed. The release circuits 13-14 and 23-24 close and the signal circuit 31-32 opens. When the Emergency-Stop button is pressed, K1 and K2 go dead and drop out. The release circuits open, the signal circuit closes. With single-channel Emergency-Stop wiring, Category 2 in accordance with EN 954-1 is attained. Earth faults in the push-button circuit are detected.

#### Two-Channel Emergency-Stop Wiring with Manual Start (Connection diagram Fig. 4)

With two-channel Emergency-Stop wiring, to Category 4 in accordance with EN 954-1 is attained. Cross circuits between the push-button contacts and earth faults in the push-button circuit are detected.

#### Safety Sequential Circuits for Type 4 Optoelectronic Protective Devices (for example light curtains/ light grids 3RG7842)

It is possible to connect safety light barriers, Type 4, with either relay outputs (Connection diagram Fig. 6 manual reset, Fig. 9 automatic reset) or failsafe semiconductor outputs and integrated cross circuit monitoring (Connection diagram Fig. 7 manual reset, Fig. 10 automatic reset). When calculating the safety distance, the 3RG7847-4BB's regression delay of 20 ms must also be taken into consideration.

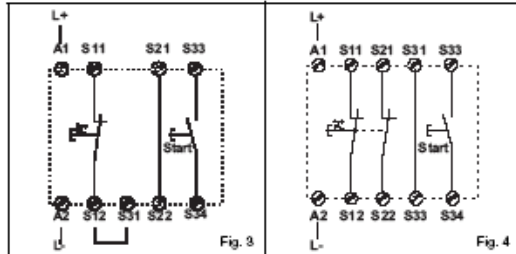

Fig. 3

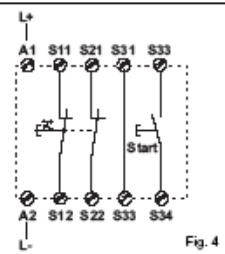

Fig. 4

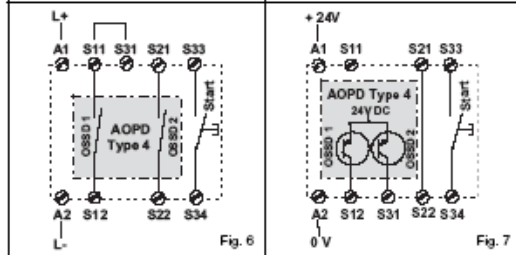

Fig. 6

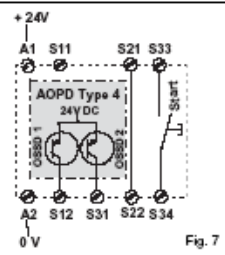

Fig. 7

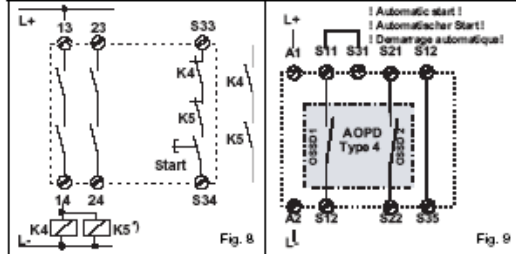

Fig. 8

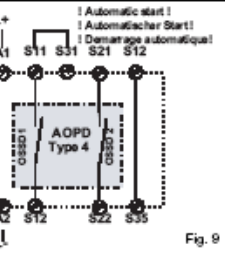

Fig. 9

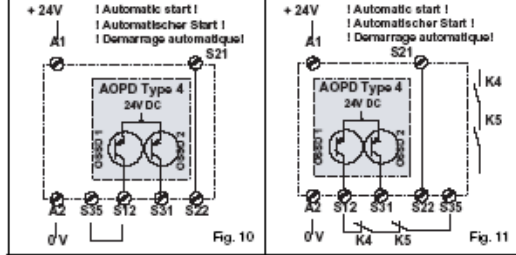

Fig. 10

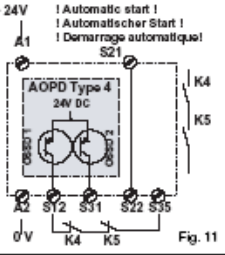

Fig. 11

<sup>1)</sup> Spare absorber  
Funkenlöschglied  
Pare-éclabou  
  
Suitable spark suppression required  
Geeignete Funkenlöschung vorzehen  
Prévoir pare-éclabou adépte

**Simultaneity monitoring**

For the activation of the function, the first signal must be supplied to terminal S12-S35 and the second to S22. The maximum permissible time displacement is 50 ms. If the switching off of the signals takes place in reversed order, simultaneity monitoring will be deactivated. Simultaneity monitoring is only active with connection for automatic start.

**Cross Circuit Monitoring**

In case of a cross circuit in the inputs S12 and S22 or a grounded short circuit in the input S12, the output relays K1 and K2 are switched off by means of an electronic fuse. The 3RG7847-4BB can resume operation approx. 2 s after the cause of the problem has been eliminated.

**Start Button Monitoring During Manual Start**  
(see, for example, Fig. 3, Fig. 4, Fig. 6, Fig. 7)

In order to detect static errors or the blocking of the start button, the button function is monitored for signal changes. The release occurs when the button is let go (1/0 signal change). This function is deactivated during automatic start (see, for example, Fig. 9, 10).

**External Contactor Monitoring (EDM) During Manual Start**  
(see Fig. 8)

So that the function of the external relays can be monitored, the normally-closed contacts of these relays are connected into the start circuit S33-S34 in series.

**External Contactor Monitoring (EDM) During Automatic Start**  
(see Fig. 11)

So that the function of the external relays can be monitored, the normally-closed contacts of these relays are connected between S12-S35 in series.

**4. Electrical Installation**  
**Installation Requirements** ⚠

- The general safety precautions in Chapter 2 must be observed.
- Enclosure ratings: housing IP 40, terminals IP 20 → must be built into an IP 54 housing!
- The power supply and the connections 13; 14; 23; 24; 31; 32 must have a safe galvanic isolation from mains voltage.
- Finger-safe in accordance with DIN VDE 0106, Section 100
- In order to prevent the output contacts from welding together, an external fuse of max. 5 A quick-action or 3.15 A delay-action must be interposed.
- Maximum stripped length of the connecting cables: 8 mm

**5. Technical Data 3RG7847-4BB**

Safety category	to cat. 4 in accordance with EN 954-1
Stop category	Stop 0 in accordance with IEC 60204-1
Opening voltage U <sub>0</sub>	24 V AC/DC, -15% bis +10%
Residual ripple (DC) / frequency (AC)	2.4 VSS / 50 - 60 Hz
Power consumption	2.1 W (AC) / 1.7 W (DC)
External fuse protection for supply circuit	1 A delay-action
Output contacts	2 normally-open contacts, 1 normally-closed contact AgSnO <sub>2</sub> gold-coated
Contacts making and/or breaking capacity in accordance with EN 60647-5-1	AC-15: 230V / 5A (*) DC-13: 24V / 3A (**) (*) 10 <sup>6</sup> operations, (**) 5 x 10 <sup>6</sup> operations
Max. permanent current per current path	3 A
External contactor fuse protection per current path	5 A quick-action or 3.15 A delay-action
Max. operations per hour	3600 operations/h
Mechanical life time	10 <sup>6</sup> operations
Pick-up delay - manual start	70 ms
Pick-up delay (autom. start)	to 230 ms
Release delay, response time	20 ms
Minimum start-up time S34, S35	80 ms
Max. test pulse acceptance	2 ms
Time window for simultaneity monitoring	50 ms
Electronic fuse readiness/recovery time	2 s / 2 s
Control voltage / current at S12, S22, S31	24V DC / 20 mA
Max. incoming current	320 mA, τ = 7.5 ms
Admissible input line resistance	< 70 Ω
Operating temperature	0° to +50° C
Storage temperature	-25° to +70° C
⚠ Overvoltage category	II for rating voltage 30V/AC according to VDE 0110 part 1
Contamination level	2
Interference emission	EN 50081-1, -2
Interference immunity	EN 50082-2
Enclosure rating	Housing IP 40, Terminals IP 20
Connecting cable cross sections	1 x 0.2 to 2.5 mm <sup>2</sup> line wired or 1 x 0.25 to 2.5 mm <sup>2</sup> line wired with multi-core cable ends 2 x 0.5 to 1.5 mm <sup>2</sup> line wired with twin multi-core cable ends 1 x 0.2 to 2.5 mm <sup>2</sup> single wired or 2 x 0.25 to 1.0 mm <sup>2</sup> line wired with multi-core cable ends 2 x 0.2 to 1.5 mm <sup>2</sup> line wired 2 x 0.2 to 1.0 mm <sup>2</sup> single wired
Dimensions (height x width x depth)	99 x 22.5 x 111.5 mm
Weight	200 g
Order Number	3RG7847-4BB